

01668E00

Terminal Boxes Series 8146

- Explosion protection according to
 - CENELEC
 - IEC
 - NEC
- For use in
 - Zone 1 and Zone 2
 - Zone 21 and Zone 22
- Fitting with terminals up to max. 300 mm²
- Enclosures made of impact-resistant, glass-fibre reinforced polyester resin
- 8 basic enclosure sizes with various heights
- Ingress Protection IP66

STAHL

Series 8146 terminal boxes are supplied with Phoenix thermoplastic terminals as standard. Terminals from other manufacturers can be fitted.

The terminal boxes are fitted to order with terminals and cable glands.

Flanges can be vitted as required on several sides of the enclosure.

Zones 1 & 2, 21 & 22



Selection Table		for terminal boxes up to max. 35 mm ² Max. number of line-up terminals which can be fitted											Order number	Weight [kg] with / without flange	
		Nominal cross-section [mm ²]													
Arrangements	UK 3 N	2.5		4		6		10		16		35			
		WDU 2.5	MXK 4	UK 5 N	WDU 4	UK 6 N	WDU 6	UK 10 N	WDU 10	UK 16 N	WDU 16	UK 35-Ex	WDU 35		
	6	--	--	--	--	--	--	--	--	--	--	--	--	8146/.031	0.64
	14	--	12	12	--	--	--	--	--	--	--	--	--	8146/.041	0.81
	19	19	16	16	16	11	12	9	9	8	--	--	--	8146/.051	0.85/ 0.95
	--	--	28	--	--	--	--	--	--	--	--	--	--	8146/.051	1.05/ 1.15
	27	28	23	23	24	17	17	13	14	11	--	--	--	8146/.061	1.06/ 1.26
	--	--	46	--	--	--	--	--	--	--	--	--	--	8146/.061	1.10/ 1.30
	--	--	46	--	--	--	--	--	--	--	--	--	--	8146/.062	1.50/ 1.70
	49	51	--	41	42	31	31	24	25	20	--	--	--	8146/.S71	1.04/ 1.70
	--	--	82	--	--	--	--	--	--	--	--	--	--	8146/.S71	1.80/ 2.20
	--	--	82	--	--	--	--	--	--	--	--	--	--	8146/.072	1.90/ 2.20
Add. to order number:															
Version:													Ex e	8146/1...	
													Ex i	8146/2...	
State with order:															
Line-up terminals:													Number and type		
Cable glands:													Number, type and installation side in enclosure		
Flanges:													Flanges can be fitted to order; please indicate the side on which they are to be fitted.		
Note:															
The order numbers contain the enclosure with carrier rails and PE or PA rail.															
Terminal boxes fitted with terminals > 35 mm ² up to 300 mm ² on request.															

Selection Table		for terminal boxes up to max. 35 mm ² Max. number of line-up terminals which can be fitted												Order number	Weight [kg]
		Nominal cross-section [mm ²]													
Arrangements	UK 3 N	WDU 2.5	4		6		10		16		35				
			MXK 4	UK 5 N	WDU 4	UK 6 N	WDU 6	UK 10 N	WDU 10	UK 16 N	WDU 16	UK 35-Ex			WDU 35
	49	51	41	41	42	31	31	24	25	20	20	--	--	8146/S73	1.40/ 1.70
	19	19	--	16	16	11	12	9	9	8	--	--	--	8146/.071	1.60/ 1.90
	51	53	--	43	44	32	33	26	26	21	--	--	--	8146/.081	2.00/ 2.40
	98	102	82	82	84	62	62	48	50	40	--	--	--	8146/.081	2.40/ 2.80
	147	153	123	123	--	--	--	--	--	--	--	--	--	8146/.081	2.80/ 3.20
	98	102	82	82	84	62	62	48	50	40	--	--	--	8146/.082	3.10/ 3.50
	51	53	43	43	44	32	33	26	26	21	22	17	16	8146/.083	2.60/ 3.00
	98	102	82	82	84	62	62	48	50	40	--	--	--	8146/.083	3.00/ 3.40
Add. to order number:															
Version:		Ex e										8146/1...			
		Ex i										8146/2...			
State with order:		Line-up terminals:		Number and type											
		Cable glands:		Number, type and installation side in enclosure											
		Flanges:		Flanges can be fitted to order; please indicate the side on which they are to be fitted.											
Note:		The order numbers contain the enclosure with carrier rails and PE or PA rail.													
		Terminal boxes fitted with terminals > 35 mm ² up to 300 mm ² on request.													



Selection Table		for terminal boxes up to max. 35 mm ² Max. number of line-up terminals which can be fitted											Order number	Weight [kg] with / without flange
		Nominal cross-section [mm ²]												
Arrangements	UK 3 N	4		6		10		16		35				
		WDU 2.5	MXK 4	UK 5 N	WDU 4	UK 6 N	WDU 6	UK 10 N	WDU 10	UK 16 N	WDU 16			UK 35-Ex
	147	153	123	123	--	--	--	--	--	--	--	--	8146/.083	3.40/ 3.80
	102	106	86	86	88	64	66	52	52	42	--	--	8146/.091	4.00/ 4.80
	196	204	164	164	168	124	124	96	100	80	--	--	8146/.091	4.80/ 5.60
	294	306	246	246	--	--	--	--	--	--	--	--	8146/.091	5.20/ 6.00
	196	204	164	164	168	124	124	96	100	80	--	--	8146/.092	6.00/ 6.80
	102	106	86	86	88	64	66	52	52	42	44	34	8146/.093	4.60/ 5.40
	196	204	164	164	168	124	124	96	100	80	--	--	8146/.093	5.40/ 6.20
	294	306	246	246	--	--	--	--	--	--	--	--	8146/.093	5.80/ 8.60
Add. to order number:														
	Version:	Ex e Ex i										8146/1... 8146/2...		
State with order:	Line-up terminals:	Number and type												
	Cable glands:	Number, type and installation side in enclosure												
	Flanges:	Flanges can be fitted to order; please indicate the side on which they are to be fitted.												
Note:	The order numbers contain the enclosure with carrier rails and PE or PA rail. Terminal boxes fitted with terminals > 35 mm ² up to 300 mm ² on request.													

Technical Data

Explosion protection	
Gas explosion protection	⊕ II 2 G Ex dem ia/ib [ia] IIA, IIB, IIC T6, T5
Dust explosion protection	⊕ II 2 D Ex tD A21 IP66 T130 °C, T95 °C, T80 °C
Ambient temperature	Type 8146/1...-: 8146/2...-: T6: Ta = - 40 °C ... + 40 °C T6: Ta = - 40 °C ... + 75 °C T5: Ta = - 40 °C ... + 55 °C
Certificates	
Gas explosion protection	PTB 01 ATEX 1016
Dust explosion protection	PTB 01 ATEX 1016
Other certificates	IECEX, China (Nepsi), Brazil (Ul do Brasil), Canada (CSA), Kazakhstan (JSC), Korea (KSG), Russia (CTB), Ukraine (ISCVE), USA (UL), GL, RS
Material	
Enclosure	Polyester resin, glass fibre reinforced, dark grey, similar to RAL 7024, impact strength ≥ 7 J, surface resistance $\leq 10^9$ Ohm, material flame resistant, self-extinguishing
Seal	Polyurethane foam
Flanges	
Standard	The enclosures are supplied without flanges in the standard version
Option	Depending on the order, the enclosures can be fitted on one or more sides with flanges; flange material: glass fibre reinforced polyester resin
Cover fixing	
Standard	M6, cheese-head screws with combined slot; captive, stainless steel
Option	with cover hinges
Rated operational voltage	max. 1100 V AC/DC (depending on terminals fitted and Ex-components)
Rated operational current	max. 500 A (depending on terminals fitted and Ex-components)
Type of Protection	IP66
Line-up terminals	max. nominal cross-section 300 mm ²

Terminal Box Fittings

Because of the contact resistances at the terminals and the leads installed in the enclosure, there is a certain power dissipation in every terminal box, which causes heating. In order to ensure that the maximum temperatures of a terminal box are not exceeded, care should be taken that the current loading of the circuits

installed in the terminal box do not exceed certain values. The maximum permitted number of conductors for individual terminal boxes, depending on the current loading and conductor cross section, can be found in the following tables.

Tables Terminal fittings, number of conductors which can be fitted depending on conductor cross-section and continuous current (continuation)

Enclosure 8146/1041

Current · Lead cross section [mm²]

[A]	1,5	2,5	4	6	10	16
3						
6						
10	44					
16	15	29	114			
20	6	17	33			
25		8	18	36		
35			5	14	35	
50				2	11	29
63					3	13
80						5
100						
125						
160						

09702E02

Enclosure 8146/1051

Current · Lead cross section [mm²]

[A]	1,5	2,5	4	6	10	16
3						
6						
10	50					
16	17	33	129			
20	7	19	37			
25		9	21	41		
35			6	16	39	
50				2	13	33
63					4	15
80						5
100						
125						
160						

09703E02

8146/1061

Current · Lead cross section [mm²**]

[A]**)	1.5	2.5	4	6	10	16	25	35
3								
6								
10	53							
16	18	35	137					
20	7	20	39					
25		9	22	43				
35			6	17	42			
50				2	13	35		
63					4	16	57	
80						6	18	64
100							7	17
125								6
160								
200								
225								
250								

09704E02

Enclosure 8146/1062

Current · Lead cross section [mm²]

[A]	1,5	2,5	4	6	10	16	25	35
3								
6								
10	64							
16	22	42	166					
20	9	25	48					
25		11	27	52				
35			8	20	51			
50				3	16	42		
63					5	19	69	
80						7	21	78
100							9	20
125								8
160								
200								
225								
250								

09705E02

Note: explanation of the tables page 9



Tables Terminal fittings, number of conductors which can be fitted depending on conductor cross-section and continuous current (continuation)

Enclosure 8146/1071 8146/1S71

Current · Lead cross section [mm²]

[A]	1,5	2,5	4	6	10	16	25	35
3								
6								
10	55							
16	19	36	142					
20	7	21	41					
25		10	23	45				
35			8	17	44			
50				2	14	36		
63					4	17	60	
80						6	18	67
100							8	17
125								7
160								
200								
225								
250								

09708E02

Enclosure 8146/1072

Current · Lead cross section [mm²]

[A]	1,5	2,5	4	6	10	16	25	35	50	70
3										
6										
10	66									
16	22	44	170							
20	9	25	49							
25		12	28	54						
35			8	21	52					
50				3	17	43				
63					5	20	71			
80						7	22	80		
100							9	21		
125								8	21	
160									7	19
200										6
225										2
250										

09707E02

Enclosure 8146/1073 8146/1S73

Current · Lead cross section [mm²]

[A]	1,5	2,5	4	6	10	16	25	35	50	70
3										
6										
10	71									
16	24	47	184							
20	10	27	53							
25		13	30	58						
35			8	22	56					
50				3	18	47				
63					6	21	77			
80						8	24	86		
100							10	22		
125								9	23	
160									8	20
200										7
225										2
250										

09708E02

Enclosure 8146/1081

Current · Lead cross section [mm²]

[A]	1,5	2,5	4	6	10	16	25	35
3								
6								
10	74							
16	25	49	192					
20	10	29	55					
25		13	31	61				
35			9	23	59			
50				3	19	49		
63					6	22	80	
80						8	25	90
100							10	23
125								9
160								
200								
225								
250								

09709E02

Note: explanation of the tables page 9

Tables Terminal fittings, number of conductors which can be fitted depending on conductor cross-section and continuous current (continuation)

Enclosure 8146/1082

Current · Lead cross section [mm²]

[A]	1,5	2,5	4	6	10	16	25	35	50	70
3										
6										
10	86									
16	29	57	221							
20	12	33	64							
25		15	36	70						
35			10	27	68					
50				4	22	56				
63					7	20	93			
80						10	29	104		
100							12	27		
125								11	28	
160									9	24
200										8
225										3
250										

09710E02

Enclosure 8146/1083

Current · Lead cross section [mm²]

[A]	1,5	2,5	4	6	10	16	25	35	50	70
3										
6										
10	91									
16	31	60	235							
20	13	35	68							
25		16	38	74						
35			11	29	72					
50				4	23	60				
63					8	28	99			
80						10	31	111		
100							13	29		
125								11	29	
160									10	26
200										9
225										3
250										

09711E02

Enclosure 8146/1091

Current · Lead cross section [mm²]

[A]	1,5	2,5	4	6	10	16	25	35
3								
6								
10	86							
16	29	57	222					
20	12	33	64					
25		16	36	70				
35			10	27	68			
50				4	22	56		
63					7	26	93	
80						10	29	104
100							12	27
125								11
160								
200								
225								
250								

09712E02

Note: explanation of the tables page 9



Tables Terminal fittings, number of conductors which can be fitted depending on conductor cross-section and continuous current (continuation)

Enclosure 8146/1092														Enclosure 8146/1093																	
Current · Lead cross section [mm ²]														Current · Lead cross section [mm ²]																	
[A]	1,5	2,5	4	6	10	16	25	35	50	70	95	120	150	185	240	[A]	1,5	2,5	4	6	10	16	25	35	50	70	95	120	150	185	240
3																3															
6																6															
10	97															10	102														
16	33	64	250													16	35	68	263												
20	13	37	72													20	14	39	76												
25		18	41	79												25		18	43	83											
35			12	31	77											35			12	32	81										
50				4	25	63										50				4	26	67									
63					8	29	105									63					9	31	110								
80						11	33	117								80						12	34	123							
100							14	31								100							15	32							
125								12	31							125								13	33						
160									10	27						160									11	29					
200										10	24	74				200										10	25	78			
225										3	13	29				225										4	14	30			
250											7	17	36			250											7	18	38		
315												3	10	22		315												4	11	23	
400														4	15	400														5	16
500															2	500															2

09713E02

09714E02



Explanation of the Tables:

As conductors there should be counted every conductor brought in and every internal connection conductor; bridges and earth conductors should not be counted.

Uncritical region (light-coloured part of table)

The light-coloured part of the table is uncritical for heating of the enclosure. Circuits classified as being in this region may be incorporated in the enclosure in any number.

Critical region (inscribed part of table)

The inscribed part of the table shows the maximum permissible number of conductors allowing for the cross section of the conductor and the continuous current loading of the conductor. When using this table, simultaneity factors and loading factors may be allowed for. Mixed arrangements with circuits of different cross sections and currents is possible; in this case the proportion of the loading from the individual circuits should be allowed for. If a terminal box is fully according to the critical of the inscribed part of the table, then any number of circuits from the uncritical region (light-coloured part of table) may be added.

Dangerous region (dark part of table)

Terminal boxes which are designed according to this part of the table would require an additional heating test.

Cable Entries

Cable entries are provided according to order. Suitable drillings are punched and the glands secured by means of counternuts. Please state required side of entry.

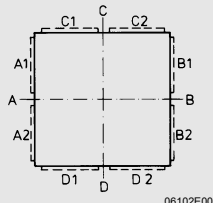

Example:
8146/.08. cable entry sides

To enter large cables into the 150 mm high enclosures, split cable entry plates with strain relief and a cut-away rubber ring are available.

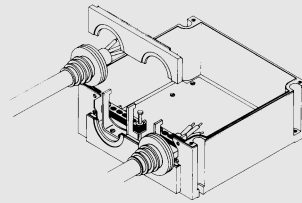

Split cable entry plate

05409E00

For metal cable glands adapter plates are available.

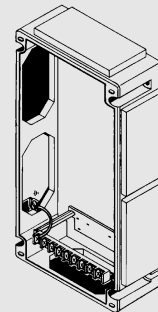

05380E00

Grounding of metal cable entry parts via brass plates

Cable glands made of moulded plastic Series 8161 are supplied as standard.

The opening of the rubber ring can be easily adapted to the diameter of the cable to be entered.

They are mounted to the inner side of the enclosure walls or flanges, thus ensuring connection to the internal earthing system.

Split Cable Entry Plate with Cable Gland for System Series 8146

Application

To enter cables with a large outside diameter in housing of the 8146 series, cable entry flanges can be used. These flanges are separable so that the cables can be inserted from the front side into the flange. A rubber sleeve which is pressed firmly to the cable by means of a hose clamp is used to seal the gap between flange and cable. In the enclosure, the cables are fixed via traction reliefs.

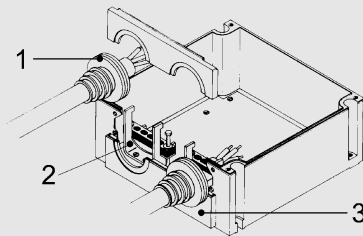

09715E00

- 1) Rubber sleeve for cable entry flange
- 2) Strain relief
- 3) Cable entry flange, separabel

Mounting

Split cable entry plates can be fitted only at that side of the enclosure which points downward and fitting is done at works. The following enclosures Series 8146 can be fitted with a split cable entry plate:

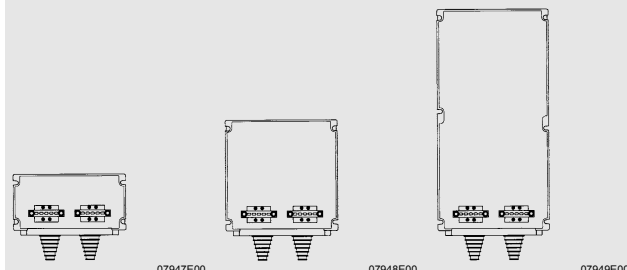

8146/.S73

8146/.083
8146/.085
8146/.086

8146/.093
8146/.095

Version

Cable entry plate fitted with:

Rubber cable seals	Cable glands	Stopping plugs
2	--	--
2	1 x M 20 x 1,5	1 x M 25 x 1,5
2	1 x M 25 x 1,5	--
2	1 x M 20 x 1,5	--
2	1 x M 25 x 1,5	--





Split Cable Entry Plate with Cable Gland for System Series 8146

Degree of protection	IP55
Rubber cable seal	black; can be cut out for cable diameter from 20 mm up to 60 mm
Cable gland	for cable diameter range 20 mm ... 40 mm 37 mm ... 64 mm

Max. Number of Mounted Cable Entries, Series 8161





Attention:

The maximum number of cable glands which can be mounted in the enclosure walls depends on the position of the components installed.

Cable gland	Enclosure size																					
 05864E00	8146/.031		8146/.041		8146/.241/.242				8146/.051/.052				8146/.061/.062				8146/.071/.072					
	without flange		without flange		without flange		with flange		without flange		with flange		without flange		with flange		without flange		with flange			
Size	A/B	C/D	A/B	C/D	A/B	C/D	A/B	C/D	A/B	C/D	A/B	C/D	A/B	C/D	A/B	C/D	A/B	C/D	A/B	C/D	A/B	C/D
M 16 x 1.5	3	6	5	8	5	10	--	7	6	8	--	7	8	10	7	7	8	18	7	14	6	6
M20 x 1.5	2	2	3	5	3	7	--	3	4	6	--	3	6	7	3	3	6	14	3	3	6	6
M25 x 1.5	1	2	2	4	2	6	--	3	3	5	--	3	5	6	3	3	5	11	3	6	6	6
M32 x 1.5	1	1	1	2	1	3	--	2	2	3	--	2	3	3	2	2	3	6	2	4	4	4
M40 x 1.5	--	1	1	1	1	2	--	2	1	2	--	2	2	2	2	2	2	4	2	4	4	4
M50 x 1.5	--	1	1	1	1	2	--	--	1	1	--	--	1	2	--	--	1	3	--	--	--	--
 05864E00	8146/.073/.075				8146/.S71				8146/.S73				8146/.081/.082									
	without flange		with flange		without flange		with flange		without flange		with flange		without flange		with flange							
Size	A/B	C/D	A/B	C/D	A/B	C/D	A/B	C/D	A/B	C/D	A/B	C/D	A/B	C/D	A/B	C/D	A/B	C/D	A/B	C/D	A/B	C/D
M 16 x 1.5	20	45	12	32	6	20	--	14	13	50	--	32	18	20	14	14						
M20 x 1.5	13	28	9	19	4	16	--	6	9	32	--	19	14	16	6	6						
M25 x 1.5	10	22	6	14	3	13	--	6	8	26	--	14	11	13	6	6						
M32 x 1.5	6	12	4	10	2	7	--	4	4	15	--	10	6	7	4	4						
M40 x 1.5	4	8	2	5	1	5	--	4	2	10	--	5	4	5	4	4						
M50 x 1.5	2	6	1	3	1	4	--	--	1	7	--	3	3	4	--	--						
M63 x 1.5	1	3	1	2	--	--	--	--	1	4	--	2	--	--	--	--						
 05864E00	8146/.083/.085/.086				8146/.091/.092				8146/.093/.095													
	without flange		with flange		without flange		with flange		without flange		with flange		without flange		with flange							
Size	A/B	C/D	A/B	C/D	A/B	C/D	A/B	C/D	A/B	C/D	A/B	C/D	A/B	C/D	A/B	C/D	A/B	C/D	A/B	C/D	A/B	C/D
M 16 x 1.5	45	50	32	32	20	38	14	28	50	91	32	64										
M20 x 1.5	28	32	19	19	16	20	6	12	32	60	19	38										
M25 x 1.5	22	26	14	14	13	23	6	12	26	46	14	28										
M32 x 1.5	12	15	10	10	7	12	4	8	15	26	10	20										
M40 x 1.5	8	10	5	5	5	9	4	8	10	18	5	10										
M50 x 1.5	6	7	3	3	4	7	--	--	7	13	3	6										
M63 x 1.5	3	4	2	2	--	--	--	--	4	6	2	4										



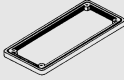

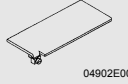

Accessories and Spare Parts					
Designation	Illustration	Description	Order number	Weight kg	
Flanges	 05742E00	Size 1 2.8 mm thick	135978	0.065	
		Size 1 5.8 mm thick	136032	0.106	
		can be mounted on enclosure enclosure side 8146/.051 /.052 C / D 8146/.061 /.062 A / B / C / D 8146/.071 /.072 A / B / C / D 8146/.S71 C / D 8146/.081 /.082 A / B / C / D 8146/.091 /.092 A / B / C / D			
	 05741E00	Size 2 2.8 mm thick	136045	0.160	
		Size 2 5.8 mm thick	136083	0.317	
		can be mounted on enclosure enclosure side 8146/.073 /.075 C / D 8146/.S73 C / D 8146/.083 /.085 /.086 A / B / C / D 8146/.093 /.095 A / B / C / D			
	 05743E00	Size 3 2.8 mm thick	136199	0.120	
		Size 3 5.8 mm thick	136237	0.190	
		can be mounted on enclosure enclosure side 8146/.073 /.075 A / B			
	Sealing frames	 04901E00	Size 0 (68 mm x 68 mm)	136012	0.010
			Size 1 (68 mm x 128 mm)	135974	0.020
			Size 2 (126 mm x 266 mm)	136031	0.040
			Size 3 (126 mm x 126 mm)	136235	0.100
	Brass plates 2 mm for flanges ^{1) 2)}	 04902E00	for flange size 1 (68 mm x 128 mm)	136888	0.040
			for flange size 2 (126 mm x 266 mm)	136960	0.220
for flange size 3 (126 mm x 126 mm)			136963	0.120	
Brass plates 3 mm for flanges ¹⁾	 04902E00	for flange size 1 (68 mm x 128 mm)	136201	0.200	
		for flange size 2 (126 mm x 266 mm)	136568	0.100	
		for flange size 3 (126 mm x 126 mm)	136726	0.320	

Accessories and Spare Parts					
Designation	Illustration	Description	Order number	Weight kg	
Brass plates 2 mm for enclosures ^{1) 2)}		for enclosure	enclosure side		
		8146/.031 8146/.041	C / D A / B	136940	0.040
		8146/.041	C / D	136945	0.060
		8146/.051 / .052 8146/.S71	A / B A / B	136914	0.050
		8146/.051 / .052 8146/.061 / .062 8146/.071 / .072	C / D A / B A / B	136921	0.070
		8146/.061 / .062	C / D	136933	0.080
		8146/.071 / .072 8146/.081 / .082 8146/.091 / .092	C / D A / B C1 / D1	136927	0.140
		8146/.073	A / B	136975	0.140
		8146/.073 8146/.083 8146/.093	C / D A / B C1 / D1	136977	0.270
		8146/.S71 / .082 8146/.081 8146/.091	C / D C / D A / B	136950	0.160
		/ .092			
		8146/.S73	A / B	136973	0.100
		8146/.S73 8146/.083 8146/.093	C / D C / D A / B	136979	0.310
		8146/.091 / .092	C2 / D2	136957	0.160
		8146/.093	C2 / D2	136982	0.310

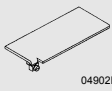

Accessories and Spare Parts							
Designation	Illustration	Description	Order number	Weight kg			
Brass plates 3 mm for enclosures ¹⁾		for enclosure enclosure side		--			
		8146/.031 C / D 8146/.041 A / B	136395	0.100			
		8146/.041	C / D	136403	0.160		
		8146/.041	C / D	136635	0.150		
		8146/.051 /052 8146/.S71 A / B	A / B A / B	136240	0.140		
		8146/.051 /052 8146/.061 /062 8146/.071 /072	C / D A / B A / B	136283	0.200		
		8146/.051 /052 8146/.061 /062 8146/.071 /072	C / D A / B A / B	136430	0.560		
		8146/.061 /062	C / D	136374	0.200		
		8146/.071 /072 8146/.081 /082 8146/.091 /092	C / D A / B C 1 / D1	136313	0.400		
		8146/.071 /072 8146/.081 /082	C / D A / B	136451	0.560		
		8146/.073	A / B	136616	0.410		
		8146/.073	C / D	136631	0.770		
		8146/.073 8146/.083 8146/.093	C / D A / B C1 / D1	136621	0.810		
		8146/.S71 8146/.081 /082 8146/.091 /092	C / D C / D A / B	136544	0.460		
		8146/.S73	A / B	136611	0.265		
		8146/.S73 8146/.083 8146/.093	C / D C / D A / B	136626	0.880		
		Shakeproof washer, galvanized		for M 25 1 pc.	110706	0.009	
				for M 32 1 pc.	110707	0.007	
				for M 40 1 pc.	110708	0.021	
				for M 50 1 pc.	110709	0.040	
for M 63 1 pc.	110710			0.060			
¹⁾ For earthing metal gland parts when used in moulded plastic enclosures and plastic flanges							
²⁾ - If the connecting line has an armouring which is bigger than 6 mm ² and which will be used as an earth connection, brass plate 3 mm has to be used. - Due to higher strain on the enclosure wall and the 3 mm brass plate has also to be used with large bell mouthed glands.							

Dimensional Drawings (All Dimensions in mm) - Subject to Alterations

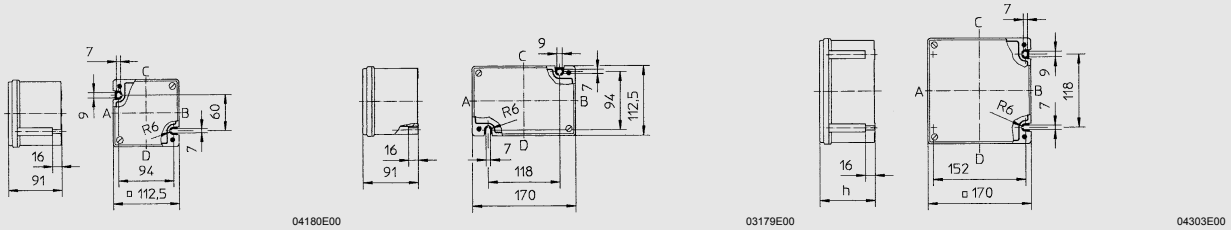

8146/03.

8146/04.

8146/05.

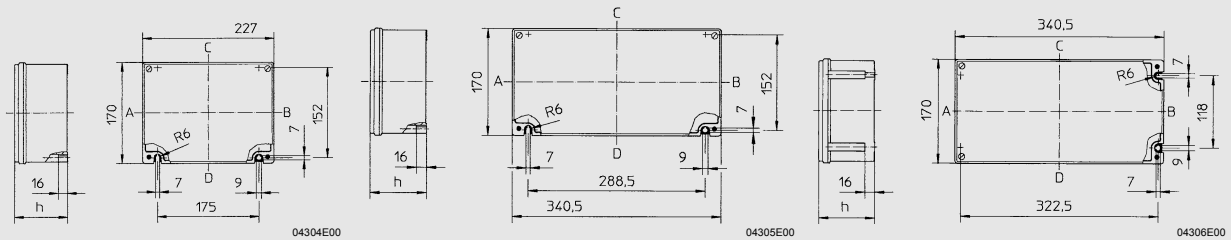

8146/06.

8146/07.

8146/S7.

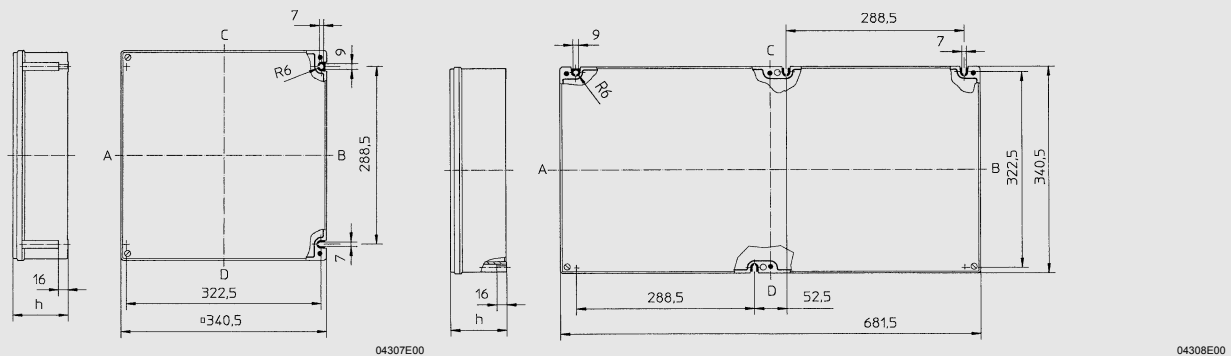

8146/08.

8146/09.

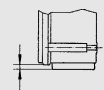
		Height of enclosure h					
		Enclosure	8146/...1	8146/...2	8146/...3	8146/...5	8146/...6
			91 mm	131 mm	150 mm	190 mm	230 mm
	Flange thickness [mm]						
	Measure a [mm]						
04309E00	2.8		X	-	-	-	-
	5.8		X	-	-	-	-
Additional dimensions for flange mounting							
			X	X	X	X	-
			X	-	X	-	-
			X	X	X	X	X
			X	X	X	X	-

X ... can be supplied

We reserve the right to make alterations to the technical data, weights, dimensions, designs and products available without notice. The illustrations cannot be considered binding.