



07244E00

Ex i Field Device Coupler 8 Spurs Series 9411/21

- For FOUNDATION™ fieldbus H1 and Profibus PA
- Connection of up to 8 intrinsically safe FISCO field devices to a non-intrinsically safe / Ex e / Nonincendive fieldbus
- Isolation between intrinsically safe field devices and non-intrinsically safe fieldbus
- Spur protection for each spur
- Reduced starting and low fault current through power management
- LED indication of status and faults on each spur
- Switchable termination on board
- Screw or cage clamp terminals
- Customer specific enclosures available in different versions



The Ex i Field Device Couplers connect up to 8 intrinsically safe FOUNDATION™ fieldbus H1 or Profibus PA field devices to a non-intrinsically safe / Ex e / Nonincendive fieldbus (high energy trunk). The intrinsically safe spurs comply with FISCO specifications and are electrically isolated from the trunk. The Field Device Couplers feature a power management to minimize current from the trunk.

The couplers are mounted on DIN rail or directly in enclosures made of glass fibre reinforced polyester or stainless steel. The cable shields can be connected to earth capacitively at the terminals or directly at the cable screen bus bar. An IP30 cover protects the non-intrinsically safe connections of the trunk so that work can be carried out at any time on the intrinsically safe spurs and field devices.

Zone	0	1	2	20	21	22
Class	I			NEC 506		
Zone	0	1	2	20	21	22
Ex interface	X	X	X	X	X	X
Installation in		X	X		X	X

Class	I		II / III	
Division	1	2	1	2
Ex interface	X	X	X	X
Installation in		X		X

Selection Table				
Version	Field enclosure	Number of channels (spurs)	Terminals	Order number
Field Device Coupler without enclosure	without, DIN rail mount	8	screw terminals	9411/21-210-41
			spring cage terminal	9411/21-220-41
Field Device Coupler in the standard enclosure	made of polyester	8	screw terminals	9411/21-211-41
			spring cage terminal	9411/21-221-41
	made of stainless steel	8	screw terminals	9411/21-212-41
			spring cage terminal	9411/21-222-41

Explosion Protection	
Certificates	
IECEX	IECEX BVS 08.0057 X
Europe (ATEX)	BVS 06 ATEX E 004 X
USA (NEC)	3026646 (FM)
Other countries	Brazil (INMETRO), Canada (cFM), Kazakhstan (JSC), Belarus (Promatomnadzor)
Marking	
IECEX	
Coupler mounted on DIN rail	
Gas explosion protection	Ex mb e ib [ia Ga] IIC T4 Gb
Dust explosion protection	[Ex ia Da] IIIC
Coupler in the standard enclosure	
Gas explosion protection	Ex mb e ib [ia Ga] IIC T4 Gb
Dust explosion protection	Ex tD A21 IIIC IP6X T80 °C Db [ia Da]
Europe (ATEX)	
Coupler mounted on DIN rail	
Gas explosion protection	⊕ II 2 (1) G Ex mb e ib [ia Ga] IIC T4 Gb
Dust explosion protection	⊕ II (1) D [Ex ia Da] IIIC
Coupler in the standard enclosure	
Gas explosion protection	⊕ II 2 (1) G Ex mb e ib [ia Ga] IIC T4 Gb
Dust explosion protection	⊕ II 2 (1) D Ex tD A21 IIIC IP6X T80 °C Db [ia Da]
USA (NEC)	see certificate
Installation	in Zones 1 and 2, Zones 21 and 22 (dust), Class I, Zones 1 and 2, Class I Division 2 and in the safe area suitable enclosure necessary (e.g. R. STAHL Series 8146 or Series 8125)
Safety data (CENELEC) each Spur	
	FISCO (IEC 60079-27)
Max. voltage U_o	15.7 V
Max. current I_o	245 mA
Max. power P_o	960 mW
Max. connectable capacitance C_o for IIC / IIB	476 nF / 2878 nF
Max. connectable inductance L_o for IIC / IIB	0.58 mH / 2.9 mH
Max. internal capacitance C_i	1.1 nF
Max. internal inductance L_i	~ 0 mH
Isolation voltage U_m	253 V



Technical Data

Power supply	not needed, the Field Device Coupler is powered from the trunk			
Galvanic isolation	Test voltage acc. to EN 50020			
Ex i spurs to Ex e trunk	1.5 kV AC			
Ex i spur to Ex i spur	no isolation			
Data transmission	passive, no repeater function			
between trunk and spurs				
Trunk, non-intrinsically safe / Ex e				
Connections	2 trunk connections (in, out), internally interconnected			
Voltage range	16 ... 32 V			
Undervoltage monitoring	U < 16 V, spurs deenergized			
Max. current consumption		at 16 V	at 24 V	at 32 V
	0 mA each spur	32 mA	26 mA	23 mA
	20 mA each spur	223 mA	147 mA	112 mA
	7 spurs each at 20 mA, 1 spur with short-circuit	265 mA	172 mA	130 mA
	all spurs with short-circuit	< 90 mA	< 70 mA	< 60 mA
Max. power dissipation	1.8 W			
Indication	LED green „PWR“ (U ≥ 16 V on trunk)			
Reverse polarity protection	yes			
Max. number of Field Device Couplers	4 per trunk			
Terminating resistor	The Field Device Couplers have a built-in, switchable termination resistor 100 Ω + 1 µF (IEC 61158-2). A jumper between terminals TERM 1 and 2 connects termination to the trunk. As an alternative, it is also possible to use an external terminating resistor Series 9418.			
Spurs, intrinsically safe FISCO Ex i				
Number	8			
Max. cable length	120 m / 394 ft			
Output voltage	≥ 10 V at 40 mA per spur			
Current range	0 ... 41 mA per spur, max. 160 mA for 8 spurs			
	Detailed planning should be made using the Fieldbus Wizard (www.fieldbus-solutions.info).			
Min. no-load voltage	12 V			
Max. internal resistance	65 Ω			
Max. short-circuit current	50 mA			
Indication each spur	LED yellow „S1“ ... „S8“			
Earthing of cable shields (trunk and spurs)				
Direct earthing	on grounding bar			
Capacitive earthing	via 4.7 nF at terminal „S“; (grounding bolt M6)			
Power management	When the trunk voltage exceeds 16 V the spurs are energized one after the other to avoid high starting current resulting from field devices. A short circuit detected on a spur will deenergize the respective spur until the short-circuit is removed. Regardless how many spurs are short-circuited the trunk is loaded with max one spur short-circuit current. Thus the trunk current and the device power dissipation are minimized under all conditions.			

Technical Data

Fault detection

Spur short-circuit	≥ 42 ... 50 mA
Indication of short-circuit per spur	LED yellow „S1“ ... „S8“, blinking
Composite error message	LED red „ERR“, blinking
Indication of spur causing overload	LED yellow "S1" ... "S8" blinking quickly
Error indication Field Device Coupler	LED red „ERR“

Electromagnetic compatibility

Tested to the following standards and regulations:
EN 61326 (IEC/EN 61000-4-1...6 and 11; EN 55022 class B);
NAMUR NE 21 (IEC/EN 61000-4-1...6, 8 and 11; EN 55022 class B)

Ambient conditions

Ambient temperature	Coupler mounted on DIN rail: - 40 ... + 75 °C / - 40 ... + 167 °F
	Coupler installed in the standard enclosure: - 20 ... + 70 °C / - 4 ... + 158 °F

Storage temperature - 40 ... + 75 °C / -40 ... +167 °F

Relative humidity (no condensation) < 95 %

MTBF (to SN 29500)

109 years

Connection diagram

Foundation Fieldbus H1
or Profibus P A
Field devices

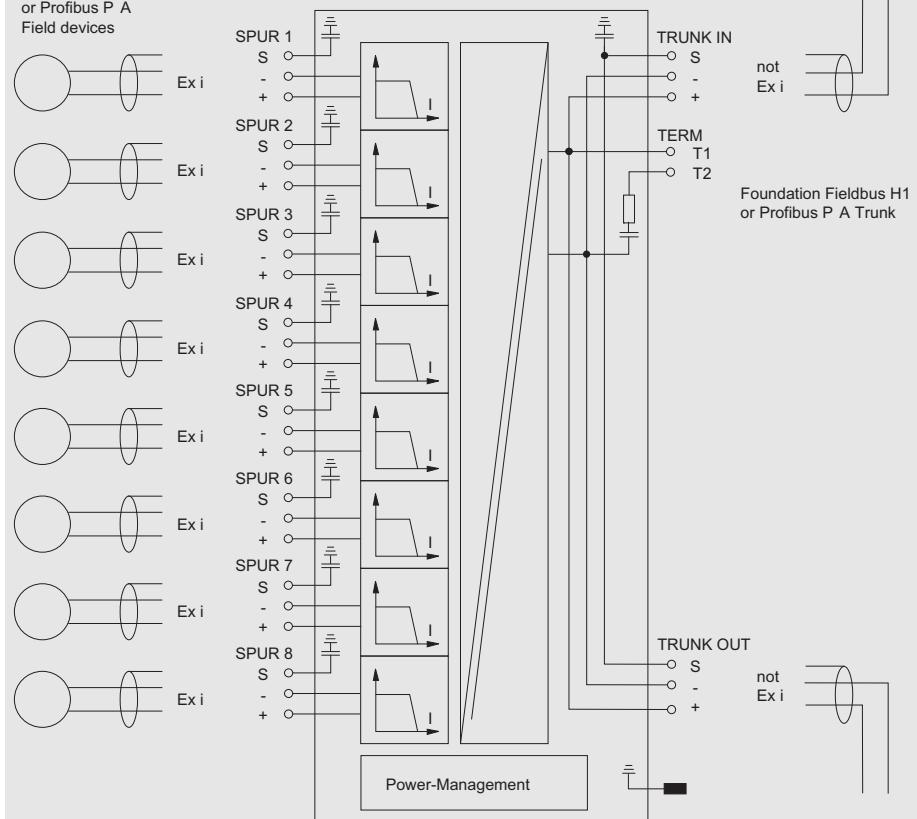





06799E02



Technical Data

Mechanical data				
Terminals	3 pole (+, -, screen)	screw terminals	spring cage terminals	
		trunk Ex e spurs Ex i	trunk Ex e spurs Ex i	
	rigid	0.2 ... 4 mm ² / 24 ... 12 AWG	0.5 ... 2.5 mm ² / 20 ... 14 AWG	0.08 ... 2.5 mm ² / 28 ... 14 AWG
	flexible	0.25 ... 2.5 mm ² / 22 ... 14 AWG	0.5 ... 2.5 mm ² / 20 ... 14 AWG	0.08 ... 2.5 mm ² / 28 ... 14 AWG
	flexible, end covering sleeves	0.25 ... 2.5 mm ² / 22 ... 14 AWG	0.5 ... 1.5 mm ² / 20 ... 16 AWG	0.08 ... 1.5 mm ² / 28 ... 16 AWG
Weight	9411/21-2.0-41: 0.89 kg / 1.96 lbs 9411/21-2.1-41: 2.35 kg / 5.18 lbs 9411/21-2.2-41: 4.29 kg / 9.46 lbs			
Assembly type	on DIN rail, EN 50022 (NS 35/15, NS 35/7.5) or mounting plate			
Installation position	vertical or horizontal			
Degree of protection				
Enclosure	IP30			
Intrinsically safe terminals	IP20			
Ex e terminals	IP30, cover closed (enclosure may be opened in hazardous area under voltage)			
Fire protection class (UL-94)	HB			
Field Device Coupler in the standard enclosure				
Version	material	enclosure Series	Field Device Coupler	
	polyester	8146/.S71	9411/21-211-41 9411/21-221-41	
	stainless steel	8125/.071	9411/21-212-41 9411/21-222-41	
Degree of protection	IP66			
Cable entries	cable glands Series 8161	8 x M20 blue (Ex i spurs) 2 x M20 black (Ex e trunk) 1 x M16 black (earth)		
	breathing gland Series 8162	1 x M25		

Accessories and Spare Parts				
Designation	Illustration	Description	Order number	Weight kg / lbs
Terminator	 06501E00	Fieldbus Terminator "Ex m"	9418/01-201-10	0.080 / 0.176
		Fieldbus Terminator "Ex i"	9418/02-201-10	0.080 / 0.176
Fieldbus Wizard Engineering Tool	 07376E00	Engineering tool for segment design of Fieldbus Foundation or Profibus PA Fieldbus segments Download under www.fieldbus-solutions.info	Download under www.fieldbus-solutions.info	
Fieldbus Power Supply	 12783E00	fieldbus power supply and diagnostics	9412/00-310-11s	0.135 / 0.298
	 12809E00	fieldbus power supply, diagnostics and adjustable warning level	9412/00-320-11s	0.135 / 0.298



Dimensional Drawings (All Dimensions in mm / inches) - Subject to Alterations

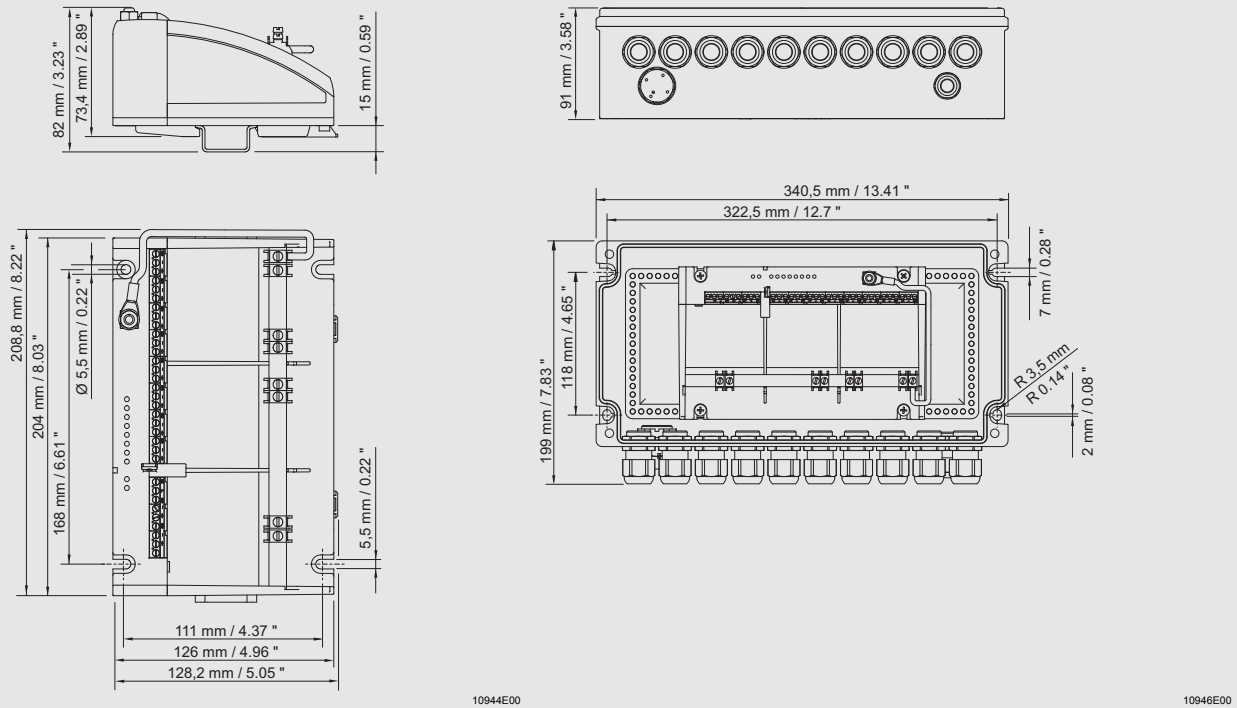

9411/21-210-41 and 9411/21-220-41
Field Device Coupler without enclosure

9411/21-211-41 and 9411/21-221-41
Enclosure 8146/.S71 incl. Field Device Coupler

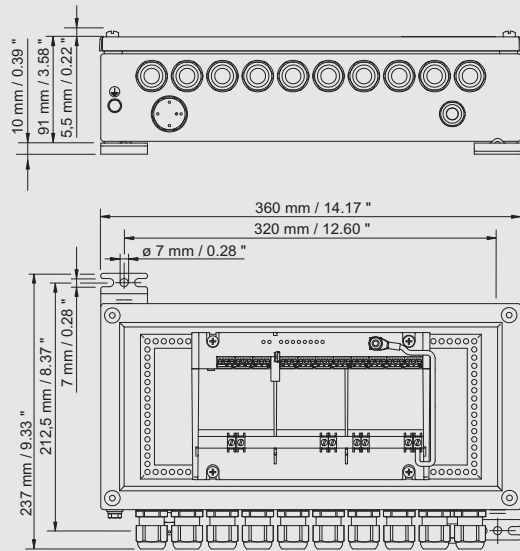

9411/21-212-41 and 9411/21-222-41
Enclosure 8125/.071 incl. Field Device Coupler



We reserve the right to make alterations to the technical data, dimensions, weights, designs and products available without notice. The illustrations cannot be considered binding.