



DIABOX 137

Made of hot-pressed glassfibre reinforced polyester
Continuous double seal (a mechanical one in the form of a tongue and groove and another in the form of an inserted EPDM seal)

Two-part construction, split diagonally, lower part for installation of equipment, upper part as lid.

Stackable design for space saving storage and transport
Approved by „Lloyds of Germany“

Hardly inflammable and self-extinguishing

- Colour: similar light grey, RAL7032
- UV-resistant
- Protection class IP 65
- Weight approx 10,8 kg

Dimensions (approx.)	H x W x D	
<input type="checkbox"/> Mounting "vertical"	490 x 710 x 390 mm	
<input type="checkbox"/> Mounting "horizontal"	390 x 710 x 490 mm	

Heat transition coefficient K	without window	with window
without Insulation	7,5 W/K	8,2 W/K
arctic-..	1,2 W/K	1,9 W/K

Accessories (see catalogue and price lists)

Standard

- SV4** 4 clasps in stainless steel

View: Mounting „vertical“

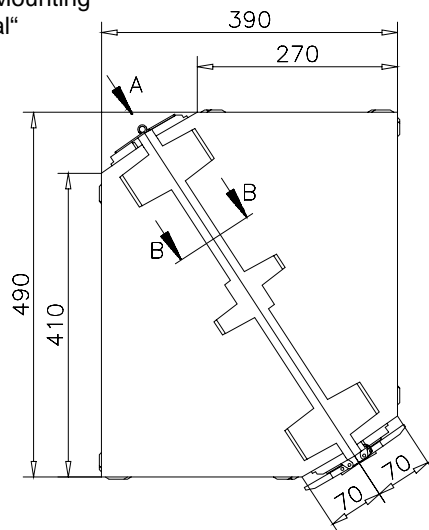

Detail: Stacking Ledges

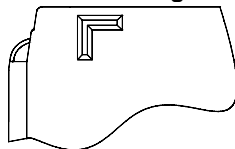

Detail B-B: Sealing Strip

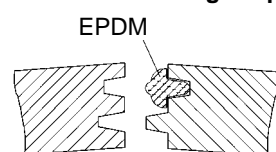

Optional designs

- SE2** 2 hinges and 2 clasps in stainless steel
- DF2** 2 lid propstay in galvanized steel, fitted
- DFVA2** 2 lid propstay in stainless steel, fitted
- DFGF2** 2 lid propstay, gas compression spring
- FAV** acrylic glass window, 300x500 mm for mounting "vertical"
- FAH** acrylic glass window, 210x500 mm for mounting "horizontal"
- FSV** safety glass window, 300x500 mm for mounting "vertical"
- FSH** safety glass window, 210x500 mm for mounting "horizontal"

arctic Insulation

PU-foam, not stackable

- arctic-PP** Polypropylene-lining
- arctic-Alu** Alu-foil lining
- GO** antistatic to avoid electrostatic charges according to EN IEC 60079-0
- EEx p** preparation for pressurised acc. to EN 50016, PTB No. Ex-84/1118X

increased Protection class

- IP66/67** **IP68**

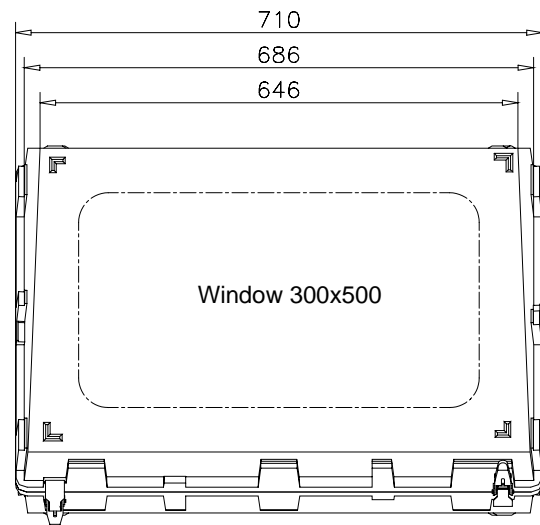

View A

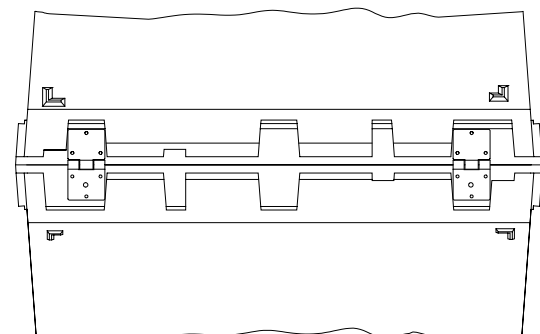

Outside Dimensions of the Enclosure - 6mm
= Inside Dimensions of the Enclosure