

Engineering Guideline

Intrinsically safe isolators ISpac

for Emerson DeltaV SIS





A unique solution designed for the DeltaV SIS

The complete solution – pac-Carrier and the specified Ex i / I.S. isolators – has been designed in cooperation with Emerson's DeltaV SIS specialists. The isolators for the discrete input and discrete output have been modified according to the requirements of safety related applications. The results are isolators which offer so-called line fault transparency.

In contrast to usual isolators these new devices are able to detect short circuit or line break in the field and report those failures back to the DeltaV SIS system directly via the signal channel. For analogue signals as well as for discrete signals the operator of the DeltaV SIS gets access to the condition of all field circuits no matter if a Ex i / I.S. isolation is required or not.

The pac-Carrier has been customized in several steps to the specific needs of the DeltaV SIS system. It allows for maximum flexibility. Each slot of the pac-Carrier can be equipped individually with the isolator corresponding to the channel type configured in the DeltaV SIS Logic Solver. As a result the pac-Carrier can be adapted to any I/O configuration of the DeltaV SIS Logic Solver. Non Ex i / I.S. signals can be easily integrated by means of an additional terminal block.

Test accomplished

In order to ensure a reliable interworking with the DeltaV SIS system the ISpac solution was thoroughly tested by Emerson. The solution passed the test.

Integrated solution pac-Carrier and single channel Ex i / I.S. isolator

Your benefits

- A flexible system for the integration of Ex i / I.S. signals
- Tested by Emerson's DeltaV SIS specialists for compatibility
- Complete line fault transparency - no blind spots
- Compact and rugged installation
- Zone 2 / Div 2 installation for DeltaV SIS and Ex i / I.S. isolation made by STAHL

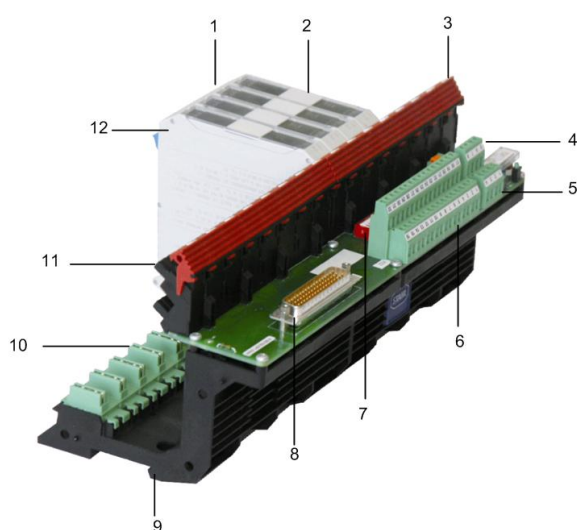

Example of 16 slots pac- Carrier

1. Detachable connectors
 - Screw terminals
 - Cage clamp terminals
2. Labeling for module, slot and carrier
3. Ejector mechanism
4. Redundant and fused supply
5. Power supply failure and line fault signaling via relay contact
6. Additional interface for field signal connection w/o Ex i / I.S. isolator
7. DIP switch for selection between AI, AO, DI or DO.
8. System cable plug
9. Installation on DIN rail or mounting plate
10. Integrated pac bus for power supply and line-fault signaling
11. Reliable snap-in mechanism, without tool
12. Single slot, any signal mixture

Stand-alone isolators on DIN rail

R.STAHL's compact ISpac Ex i / I.S. isolator system provides the entire, sophisticated functionality required for process automation and safety systems in hazardous locations subject to the risk of gas and dust explosion. It offers solutions for all conceivable requirements made of point-to-point transmission of process signals. There is a device with one or two channels for all processes and standard applications. Stand-alone application on single DIN rails, group installation of 20, 30 or more devices, transmission of HART signals or use in SIL applications: always the same design with consistent installation procedures. This drastically simplifies your planning procedures and wiring. The consequence of this flexibility is an unrivalled level of economy and efficiency.

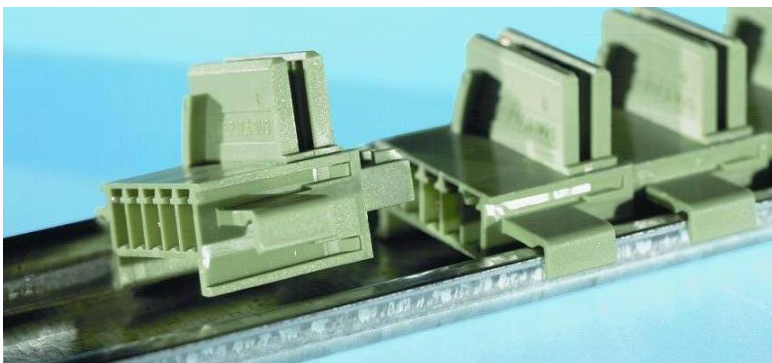
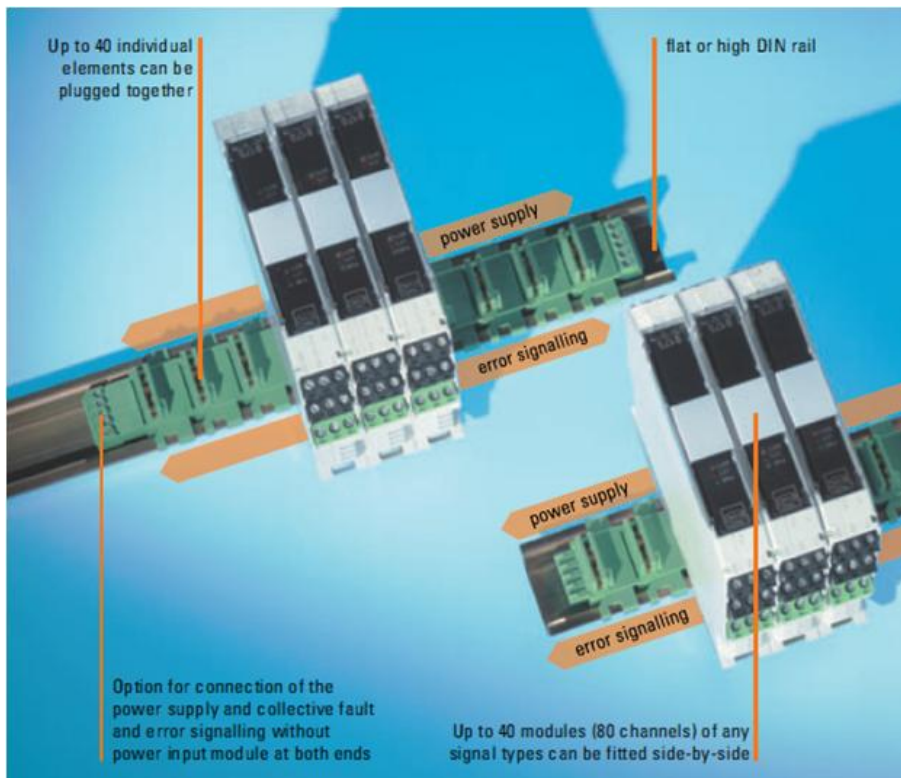

The ISpac modules are available for all functions, both as single-channel devices and as two-channel devices. Most of the components of R.STAHL's ISpac Ex i isolator system can be used in applications necessitating SIL 2 or SIL 3.

Customized solutions for Emerson

R. STAHL offers a wide range of customized solutions which allow the user to integrate field signals into Emerson’s DeltaV and DeltaV SIS in an easy and cost effective manner. The solutions designed for Emerson cover the different ways of connecting field devices to process control and safety systems nowadays.

In addition to the products the R. STAHL Competence Centre provides the full range of services: consulting, engineering, commissioning and maintenance in order to contribute to Emerson’s overall project business. We do not only regard ourselves as a manufacturer and supplier of components and systems, but also as a provider of comprehensive services.

Our engineers have many years of experience, from the engineering to the handling of the smallest details, which is beneficial for you and your customer.

R. STAHL is able to manufacture completely equipped I.S. system cabinets for control room or field installation. In addition to our approved R. STAHL standard components additional components from certified suppliers are used.

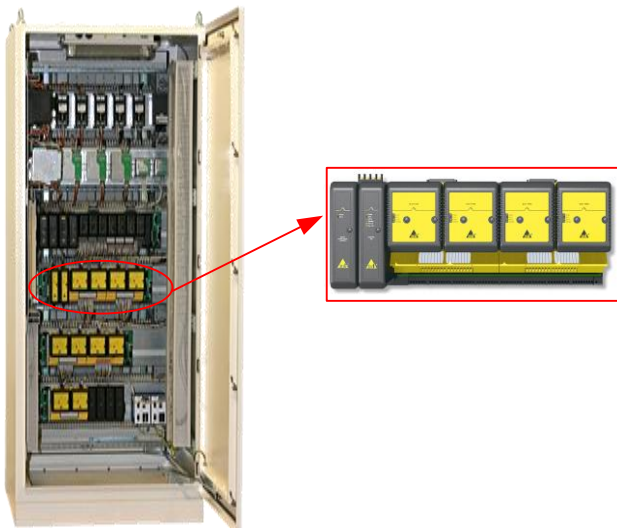

Example of a customer specific field station for an Emerson system made by STAHL

Cooperation with STAHL provides the following benefits:

- Selection of the explosion protection method which fits best your needs – technically and economically
- Competent consulting and engineering
- In-house manufacturing ensures maximum flexibility and short delivery times
- Complete range of interface solutions – barriers, isolators, remote I/O, fieldbus, HMI and CCTV



Content

Integrated solution pac-Carrier and single channel Ex i / I.S. isolator

DeltaV SIS			STAHL pac-Carrier				
Signal type	Card type	Channels	Slots	Cable type	pac-Carrier type	ISpac	page
DI, DO, AI AO	SLS 1508	16	16	9195/C-006	9195/16A-EP1-04A4	DI: 9170/10-14-12 DO: 9175/10-12-12 9175/10-14-12 9175/10-16-12 AI: 9160/13-10-11 AO: 9165/16-11-11 Rev C	7-12

Stand-alone Isolators on DIN rail (without pac-Carrier)

Signal type	Channels	Description	ISpac	page
DI	1	Switching repeater with electrical output (NAMUR	9170/10-14-12	12-15
	2	EN 60947-5-6, 35 V / 50 mA) with line fault transparency (LFT)	9170/20-14-12	
DO	1	Binary output with line fault transparency (LFT) for $I_{max} = 60$ mA	9175/10-12-12	16-27
	1	Binary output with line fault transparency (LFT) for $I_{max} = 45$ mA	9175/10-14-12	
	1	Binary output with line fault transparency (LFT) for $I_{max} = 35$ mA	9175/10-16-12	
AI	1	Transmitter supply unit 0/4 mA...20 mA with HART	9160/13-10-11	28-32
	2		9160/23-10-11	
	1/2	Transmitter supply unit with Single input 0/4 mA...20 mA and dual output with HART	9160/19-10-11	
AO	1	isolating repeater 0/4 mA...20 mA with HART	9165/16-11-11 Rev C	34-36
	2		9165/26-11-11 Rev C	

Please note: Only single channel isolators can be mounted on pac-Carrier 9195.

All types (single / dual channel / signal duplicator) can be used for DIN rail installation without pac-Carrier.

pac-Carrier
Type 9195 / 16A – EP1 – 04A4

For Emerson DeltaV SIS

- Signal types: DI, DO, AI, AO
- pac-Carrier for 16 modules, up to 16 signals
- ISpac isolators :
 - DI 9170/10-14-12
 - DO 9175/10-12-12, 9175/10-14-12, 9175/10-16-12
 - AI 9160/13-10-11
 - AO 9165/16-11-11 Rev C can be used
- Customized system cables type 9195/C-006 with Sub-D for connection on pac-Carrier and wires to the DeltaV SIS
- Redundant power supply with fault signalization contact and exchangeable fuses
- Horizontal or vertical installation
- Simple installation on DIN rail or mounting plate
- Various labeling possibilities
- Fast and reliable installation of the isolators without tools
- Comfortable exchange of the isolators with secured ejector mechanism
- Installation possible in Zone 2 and Div. 2

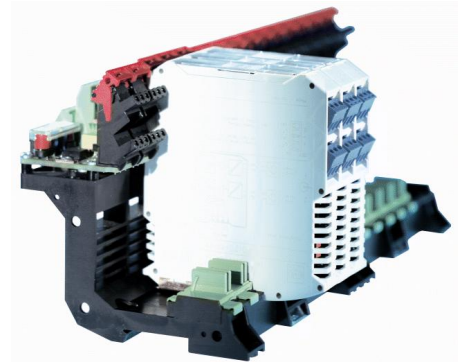

05179E00

Comfortable and simple integration of the Ex I / I.S. isolators ISpac into Emerson / DeltaV SIS safety systems via system specific connection boards and system cables.

System overview

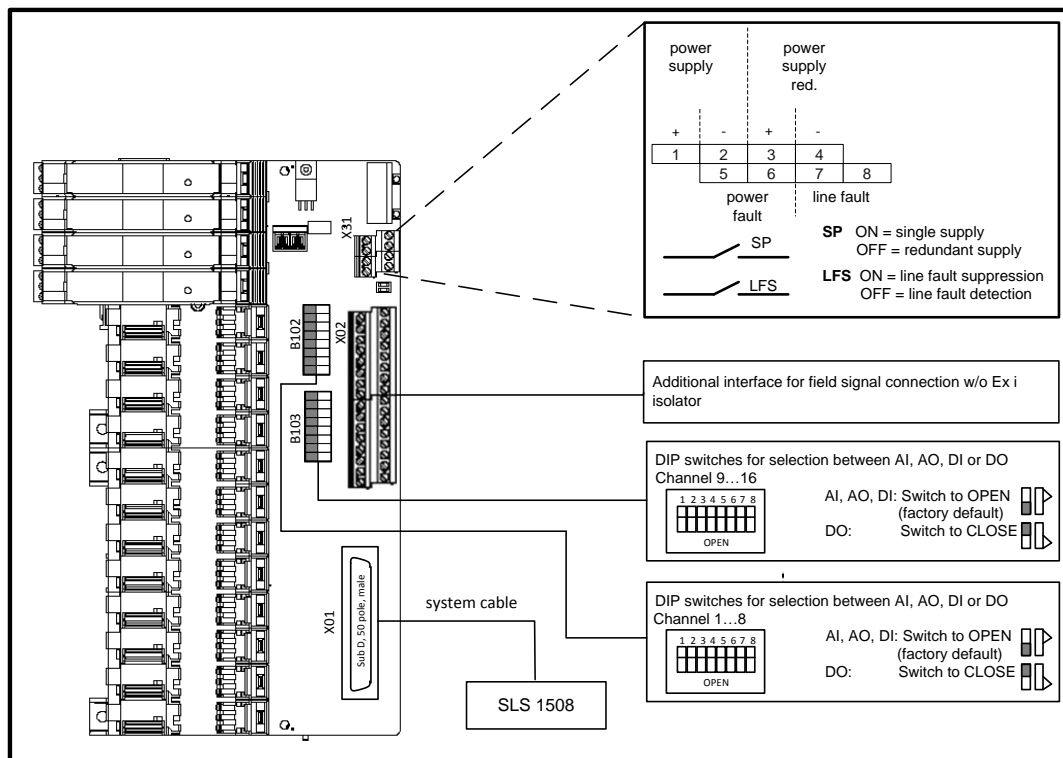

Technical data	
Certificates	BVS 03 ATEX E213 X
Explosion protection	⊕ II 3 G Ex nA nC II T4
Installation	In Zone 2, Div. 2 and in the safe area
Power supply	(X31)
Nominal voltage U_N	24 V DC (19 V ... 31,2 V)
Redundant supply	yes, decoupled with diodes
Indication	2 LED green „PWR1“; „PWR2“
Fuse	2 x TR5; T 2,0 A; exchangeable, for primary and redundant supply
Polarity reversal protection	yes
Connection to automation system	(X01)
Connection	1 x socket Sub-D 50 pole for customized cable type 9195/C-006
Number of channels	16
Connection field devices – None Ex i / I.S.	(X02)
Connection	Screw terminal
Number of channels	16 (3 PINs per channel)
Connection field devices – Ex i / I.S.	
Connection	at the terminals of the Ex i / I.S. isolators (see “signal loops”)
Number of channels	16
Error messaging	(X31)
Power supply failure PF	Contact (35 V / 100 mA), closed in good conditions
Line fault LF (of IS pac modules)	Contact (35 V / 100 mA), closed in good conditions
Setting switch „SP“	Power failure message suppressed for redundant supply (single supply)
Setting switch „LFS“	Line fault message suppressed
Ambient conditions	
Ambient temperature	max. - 20 °C ... + 70 °C (see specification of Ex I / I.S. isolators)
Storage temperature	- 40 °C ... + 80 °C
Relative humidity (no condensation)	≤95 %
Mechanical data	
Weight	approx. 320 g
Mounting type	on DIN rail (NS35 / 15, NS35 / 7.5) or mounting plate (4 x screw M6)
Mounting position	horizontal or vertical
Casing / Terminal protection class	IP 00 / IP 20
Casing material	PA 6.6
Fire protecting class (UL-94)	V0

Signal loops

The diagrams below show typical applications. Please refer to the connection list to get the entire connection scheme. Basic technical parameters of the ISpac isolating repeaters can be found at the end of this document. The detailed specifications can be downloaded at: www.ispac.info.

Switching repeater (DI)
with Line Fault Transparency
for NAMUR proximity switches and contacts
- electronic output

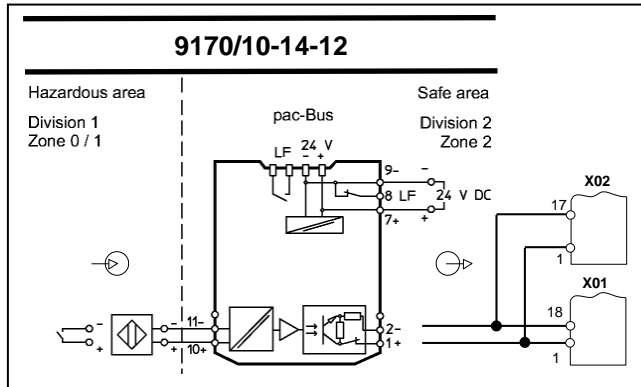

Digital output (DO)
with Line Fault Transparency
for solenoid valves and LED's

Please note, that the current of the line fault detection may cause problems with specific types of solenoid valves. Valves may not switch off even if the output of the digital output is in the operating mode OFF. In this case the line fault detection must be deactivated. See 7.2.

Please check the holding current of the solenoid valve by means of the individual spec sheet.

Line fault detection circuit ISpac 9175: Current: 0,5...1,1 mA

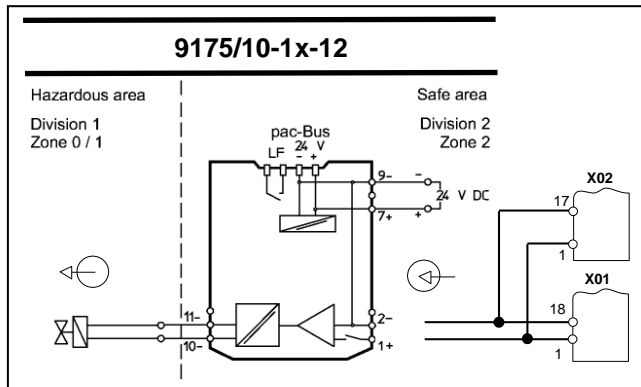

X = 2, 4 und 6

Transmitter supply unit (AI)
for 2-, 3-wire transmitter and mA sources
for 2-wire transmitter with HART

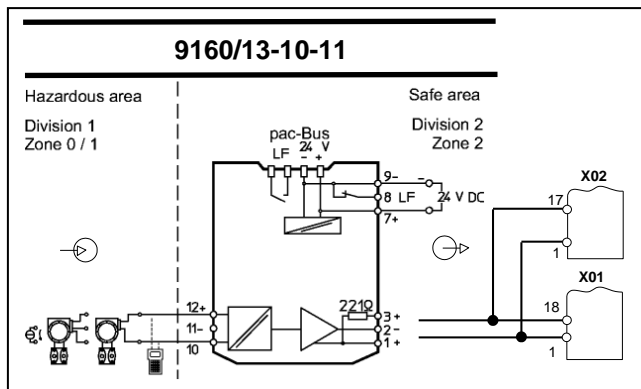

Isolating repeater (AO)
for control valves, i/p-converters or indicators
bi-directional HART communication.

For safety applications only 4...20 mA signals are permitted

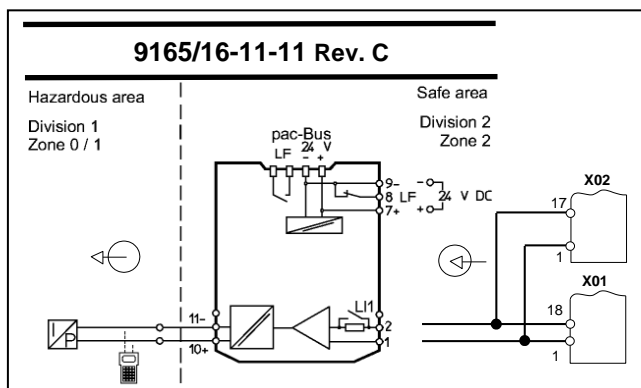

SIL specification

ISpac type	Function	SIL	Tested by	Test report Number	SFF	PFD	Tproof
9170/10-14-12	DI	2	EXIDA	Stahl 05/08-34 R009 (V2, Rev. R1)	89%	6,25E-04	5
9175/10-1x-12	DO	2	EXIDA	Stahl 07/10-01R012 (V1, Rev. R0)	97%	3,85E-04	5
9160/13-10-11	AI	2	EXIDA	Stahl 05/08-34 R008 (V2, Rev. R3)	73%	4,46E-04	1
9165/16-11-11RevC	AO	2	EXIDA	Stahl 04/04-03 R004 (V3, Rev. R0)	82%	9,51E-04	3
9195/16 A-EP1-04A4		3	EXIDA	Stahl 04/04-03 R002 (V1, Rev. R1.0)	91%	2.04E-05	10

Please find further parameters in the SIL reports. Download at www.ispac.info.

Accessories and Spare Parts

Designation	Illustration	Description	Order number
Cover yellow transparent (10 pieces)	 01955E00	The yellow covers mark the isolators used for SIL applications. Delivered in packages of 10 pieces.	200914
System cable		Customized system cables type 9195/C-006 with Sub-D for connection on pac-Carrier and wires to the DeltaV SIS. Please specify the required length.	9195/C-006

Dimension drawings (all dimensions in mm) - subject to alterations

12472E00

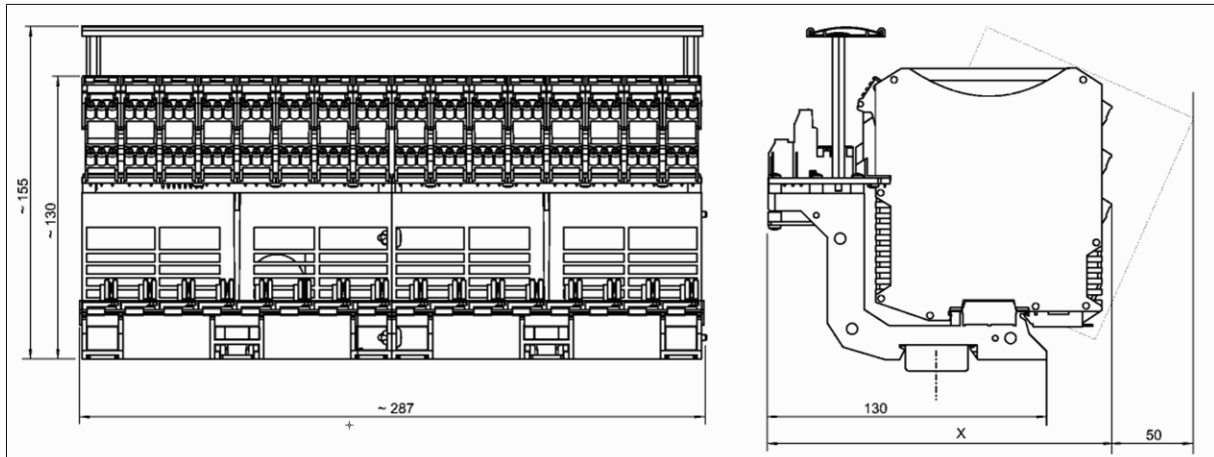

	Dimension x
Screw terminals	176 mm
Cage clamp terminals	186 mm

Please note: In order to snap in the ISpac modules an extra space of approx. 50 mm is required. Please read the "ISpac engineering guideline" carefully before you start to engineer the enclosures with incorporated ISpac modules with or without pac-Carriers. The "ISpac engineering guideline" can be downloaded from: www.ispac.info.



Connection list
Connection to field devices (Ex i / I.S.)

terminal Ex I / I.S. ISpac Modules			channel	carrier slot	input / output no.	switch no		X01 pin no (Sub-D 50)	polarity	X02 terminal no (screw)	Cable 9195/C-006 color code	SLS 1508 terminal no
DI: 9170 DO: 9175 AO: 9165	polarity	AI: 9160				B102	B103					
10	+	12	1	1	1	1		1	+	1	White	A1
11	-	10						18	-	17	Brown	B1
								34			Green	C1
10	+	12	2	2	2	2		2	+	2	Yellow	A2
11	-	10						19	-	18	Gray	B2
								35			Pink	C2
10	+	12	3	3	3	3		3	+	3	Blue	A3
11	-	10						20	-	19	Red	B3
								36			Black	C3
10	+	12	4	4	4	4		4	+	4	Purple	A4
11	-	10						21	-	20	gray-pink	B4
								37			red-blue	C4
10	+	12	5	5	5	5		5	+	5	white-green	A5
11	-	10						22	-	21	brown-green	B5
								38			white-yellow	C5
10	+	12	6	6	6	6		6	+	6	yellow-brown	A6
11	-	10						23	-	22	white-gray	B6
								39			gray-brown	C6
10	+	12	7	7	7	7		7	+	7	white-pink	A7
11	-	10						24	-	23	pink-brown	B7
								40			white-blue	C7
10	+	12	8	8	8	8		8	+	8	brown-blue	A8
11	-	10						25	-	24	white-red	B8
								41			brown-red	C8
10	+	12	9	9	9		1	9	+	9	white-black	A9
11	-	10						26	-	25	brown-black	B9
								42			gray-green	C9
10	+	12	10	10	10		2	10	+	10	yellow-gray	A10
11	-	10						27	-	26	pink-green	B10
								43			yellow-pink	C10
10	+	12	11	11	11		3	11	+	11	green-blue	A11
11	-	10						28	-	27	yellow-blue	B11
								44			green-red	C11
10	+	12	12	12	12		4	12	+	12	yellow-red	A12
11	-	10						29	-	28	green-black	B12
								45			yellow-black	C12
10	+	12	13	13	13		5	13	+	13	gray-blue	A13
11	-	10						30	-	29	pink-blue	B13
								46			gray-red	C13
10	+	12	14	14	14		6	14	+	14	pink-red	A14
11	-	10						31	-	30	gray-black	B14
								47			pink-black	C14
10	+	12	15	15	15		7	15	+	15	blue-black	A15
11	-	10						32	-	31	red-black	B15
								48			white-brown-black	C15
10	+	12	16	16	16		8	16	+	16	yellow-green-black	A16
11	-	10						33	-	32	gray-pink-black	B16
								49			blue-red-black	C16
								17 *)	--		white-green-black	(GND)
								50 *)	--		green-brown-black	(GND)

*) connector body

 We reserve the right to make alterations to the technical data, weights, dimensions, designs and products available without notice.
 The illustration cannot be considered binding.



10543E00

**Switching Repeater
with Electronic Output
(35 V / 50 mA)
with Line Fault Transparency
Type 9170/.0-14-12 LFT**

- Intrinsically safe input [Ex ia] IIC
- Galvanic isolation between input, output and power supply
- Open-circuit / short-circuit monitoring and messaging (can be switched off)
- Line fault transparency (LFT): line fault signalling directly via output on PLC / DCS
- Inversion of output signal can be set
- Transmission frequency up to 10 kHz
- Installation possible in Zone 2
- Can be used up to SIL 2 (IEC 61508)



Basic function: binary / digital input, 1 and 2 channels.
The switching repeaters are suitable typically for intrinsically safe operation of contacts, proximity switches to EN 60947-5-6 (NAMUR), optocoupler outputs etc.
The version 9175/.0-14-12 LFT is characterised by line fault transparency. This function makes it possible to signal cable faults directly to the control level via the signal channel. The Output of the switching repeater acc. to EN 90947-5-6 (NAMUR).

	Zones					
	0	1	2	20	21	22
Ex i interfaces	X	X	X	X	X	X
Installation in			X			X

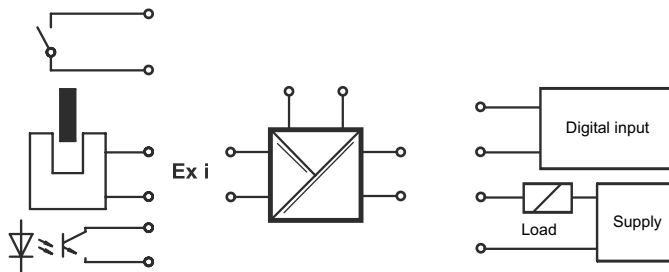

09362E02

Selection Table					
Version	Channels	Power Supply	Output / channel	Connection type	Order number
Switching repeater with electrical output with line fault transparency (35 V / 50 mA) Type 9170/0-14-12 LFT	1	24 V DC	1 electronic output NAMUR (EN 60947-5-6) (35 V / 50 mA)	Screw terminals	9170/10-14-12s
				Spring cage terminals	9170/10-14-12k
	2	24 V DC	1 electronic output NAMUR (EN 60947-5-6) (35 V / 50 mA)	Screw terminals	9170/20-14-12s
				Spring cage terminals	9170/20-14-12k

Accessories and Spare Parts		
Designation	Description	Order number
Resistance coupling element	Allows to detect short circuit or open circuit if simple contact is applied.	105944

Technical Data			
Certificates	DMT 02 ATEX E 195 X		
Other certificates	pending		
Explosion protection	Ⓜ II 3 (1) G Ex nA nC [ia] IIC T4 Ⓜ II (1) D [Ex iaD]		
Installation	in Zone 2, Div 2 and in save area		
Safe maximum values (CENELEC)	Inputs	channels single	2 channels parallel
	Max. voltage U_o Max. current I_o Max. power P_o Max. connectable capacitance IIC/IIB Max. connectable inductance IIC/IIB Intern. capacitance C_i and inductance L_i Insulation voltage U_m	10.6 V 24 mA 64 mW 2.32 μ F / 16.2 μ F 63 mH / 230 mH 2.42 nF / negligible 253 V	10.6 V 48 mA 128 mW 2.32 μ F / 16.2 μ F 16 mH / 61 mH 4.84 nF / negligible 253 V
	Further information and combinations of values, see certification.		
Power supply	Nominal voltage U_N	24 V DC	
	Voltage range Residual ripple Nominal current at U_N 1 / 2 channels Power consumption at U_N 1 / 2 channels Max. power losses 1 / 2 channels Polarity reversal protection	18 V ... 31.2 V < 3.26 V_{SS} 26 mA / 36 mA 0.6 W / 1.9 W 0.6 W / 1.9 W yes	
Ex i Input	Indication	LED green „PWR“	
	Undervoltage monitoring	yes (no faulty module / output states)	
Ex i Input	Input signal current for ON / OFF	on regulations EN 60947-5-6 (NAMUR) ≥ 2.1 mA / ≤ 1.2 mA	
	Hysteresis No-load voltage Short-circuit current Input resistance R_i	approx. 0.2 mA 8.2 V 8.2 mA 1000 Ω	
Output	maximum load DC maximum load AC maximum switching power Overload protected Voltage drop electrical life time resistive load maximum switching frequency Switching delay ON / OFF Switching delay OFF / ON Electronic output closed Electronic output opened in case of error (signalisation contact open)	35 V / 50 mA DC - - 1.75 W yes < 2 V > 10 ⁹ cycles 10 kHz 15 μ s 30 μ s R = 2.4 k Ω R > 25 k Ω R > 100 k Ω	
	Settings (switch INV) Indication	Inversion of operating mode LED yellow „OUT“ perchannel	



Switching Repeater with Electronic Output (35 V / 50 mA) with Line Fault Transparency Type 9170/0-14-12 LFT



Technical Data				
Error detection Ex i Input	Open-circuit (EN 60947-5-6) Short-circuit (EN 60947-5-6) Behaviour of output Settings (Switch LF) Error detection Error messaging and power supply failure	$I_E <$ $R_E <$	0.05 mA ... 0.35 mA 100 Ω ... 360 Ω OFF activated / deactivated LED red „LF“ each channel - Contact in the output circuit (35 V / 50 mA) opens in case of error - Contact (30 V / 100 mA) close to ground in case of error - pac-Bus, floating contact (30 V / 100 mA)	
Galvanic isolation	Test voltage under regulations EN 60079-11		1.5 kV AC 1.5 kV AC 500 V AC 1.5 kV AC	
	Test voltage under regulations EN 50178		1.1 kV AC 1.1 kV AC 350 V AC 1.1 kV AC	
Electromagnetic compatibility	Tested under the following standards and regulations: EN 61326-1 (Use in industrial environment) NAMUR NE 21			
Ambient conditions	Ambient temperature		- 20 °C ... + 60 °C / + 70 °C (see instructions)	
	Storage temperature Relative humidity (no condensation)		- 40 °C ... + 80 °C \leq 95 %	
Mechanical data		Screw terminals	Spring cage terminals	Insulation displacement connectors
	Connection one wire - rigid - flexible - flexible, end covering sleeves (without / with plastic sleeving)	0.2 ... 2.5 mm ² 0.2 ... 2.5 mm ² 0.25 ... 2.5 mm ²	0.2 ... 2.5 mm ² 0.2 ... 2.5 mm ² 0.25 ... 2.5 mm ²	-- 0.5 ... 1 mm ² --
	Connection two wires - rigid - flexible - flexible, end covering sleeves	0.2 ... 1 mm ² 0.2 ... 1.5 mm ² 0.25 ... 1 mm ²	-- -- 0.5 ... 1 mm ²	-- -- --
	Weight Mounting type		approx. 160 g on DIN rail acc. to EN 50022 (NS35/15; NS35/7.5) or in pac-Carrier	
	Mounting position Casing protection class Terminal protection class Casing material Fire protecting class (UL-94)		horizontal or vertical IP 30 IP 20 PA 6.6 V0	

Technical Data

Connection diagram

1 channel
9170/10-14-12. LFT

Hazardous area

Division 1
Zone 0 / 1

Safe area

Division 2
Zone 2

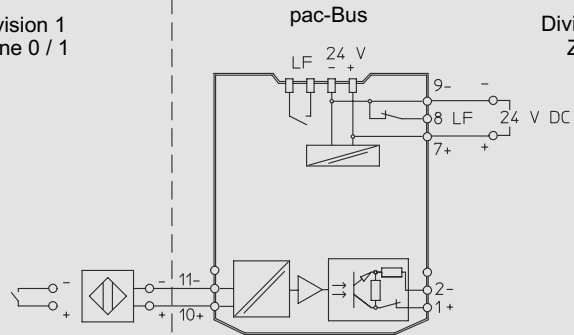

Field device

ISpac Isolator

Control system

07789E02

2 channels
9170/20-14-12. LFT

Hazardous area

Division 1
Zone 0 / 1

Safe area

Division 2
Zone 2

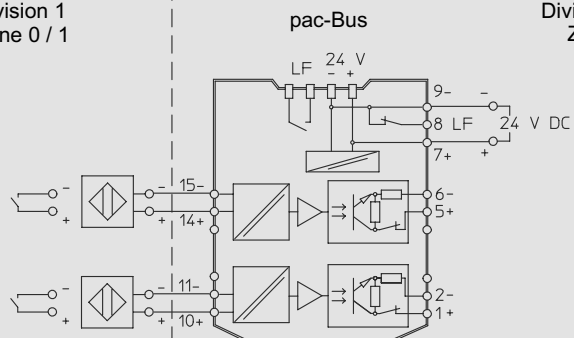

Field device

ISpac Isolator

Control system

07790E02

Dimension drawings (all dimensions in mm) - subject to alterations

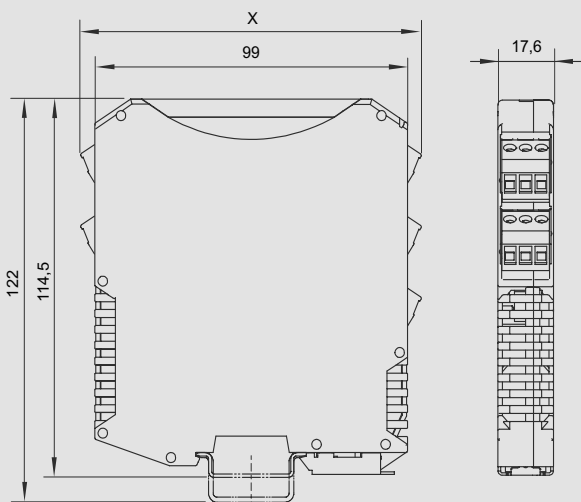

09685E00

	Dimension X
Screw terminals	108 mm
Spring cage terminals	128 mm
Insulation displacement connectors	131 mm

We reserve the right to make alterations to the technical data, weights, dimensions, designs and products available without notice. The illustrations cannot be considered binding.

Selection Table						
Version	Channels	No-load voltage U_A	Max. output current $I_{A \text{ max}}$	Internal resistance R_i	Connection type	Order number
Binary Output with Line Fault Transparency for $I_{max} = 60 \text{ mA}$ Type 9175/10-12-12 LFT	1	10 V	60 mA	150 Ω	Screw terminals	9175/10-12-12s
					Spring cage terminals	9175/10-12-12k

Technical Data													
Certificates	DMT 03 ATEX E 043 X												
Explosion protection	⊕ II 3 (1) G Ex nA nC [ia] IIC T4 and ⊕ II (1) D [Ex iaD]												
Installation	In Zone 2 and in the safe area												
Safe maximum values (CENELEC)	Max. voltage U_o 11.3 V Max. current I_o 75 mA Max. power P_o 210 mW Max. connectable capacitance IIC / IIB 1.79 μF / 12.1 μF Max. connectable inductance IIC/ IIB 6.3 mH / 25 mH Internal capacitance C_i 1.1 nF Internal inductance L_i negligible Insulation voltage U_m 253 V												
Power supply	Nominal voltage U_N 24 V DC Voltage range 18 V ... 31.2 V Residual ripple within voltage range \leq 3.6 V _{pp} Indication LED green „PWR“ Polarity reversal protection yes Undervoltage monitoring yes (no faulty module / output states)												
Current consumption	Device draws its power from auxiliary power or signal cable as a function of its switching state. <table border="1"> <thead> <tr> <th>Switching state</th> <th>Auxiliary power Rated current I_N</th> <th>Signal input Rated current I_N</th> </tr> </thead> <tbody> <tr> <td>Input = Output</td> <td></td> <td></td> </tr> <tr> <td>OFF</td> <td>30 mA</td> <td>--</td> </tr> <tr> <td>ON</td> <td>14 mA</td> <td>50 mA</td> </tr> </tbody> </table> Power consumption: 1.5 W Power loss: 1.4 W	Switching state	Auxiliary power Rated current I_N	Signal input Rated current I_N	Input = Output			OFF	30 mA	--	ON	14 mA	50 mA
Switching state	Auxiliary power Rated current I_N	Signal input Rated current I_N											
Input = Output													
OFF	30 mA	--											
ON	14 mA	50 mA											
Galvanic isolation	Test voltage under regulations EN 60079-11 Ex i output to input 1.5 kV AC Ex i output to power supply 1.5 kV AC Ex i output to error-contact 1.5 kV AC Test voltage under regulations EN 50178 Error-contact to power supply and inputs 350 V AC												
Input	Switching voltage according to EN 61131-2 Voltage for ON / OFF 18 V ... 31.2 V / 0 V ... 15 V Control current $<$ see current consumption table Input resistance R_i switching state OFF 3.5 k Ω												



Binary Output with Line Fault Transparency for $I_{max} = 60 \text{ mA}$ Type 9175/10-12-12 LFT



Technical Data

Ex i output

Output characteristic curves (at U_N ; $-20 \text{ }^\circ\text{C} \dots +60 \text{ }^\circ\text{C}$)
(more information see instructions)

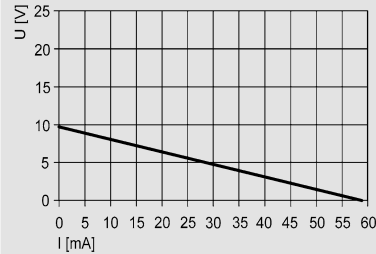

07757E00

Maximum values
each output

No-load voltage U_A 10 V
 Max. output current $I_{A \text{ max}}$ 60 mA
 Internal resistance R_i 150 Ω
 Residual ripple output $\leq 50 \text{ mV}$
 Switching delay OFF \leftrightarrow ON $\leq 1 \text{ ms}$
 Operating frequency $\leq 50 \text{ Hz}$
 Indication LED yellow „OUT“ each channel

Note

You may find a list of compatible Ex i solenoid valves on our homepage www.ispac.info.

Error detection Ex i output

Open-circuit $> 7 \text{ k}\Omega$
 Short-circuit, at $23 \text{ }^\circ\text{C}$ $< 50 \text{ }\Omega \pm 3 \text{ }\Omega / 10 \text{ K}$
 Settings (switch LF) activated / deactivated
 Error detection LED red „LF“ each channel
 Error messaging and power supply - contact on the signal input open in case of fault
 - pac-Bus, floating contact (30 V / 100 mA)



Electromagnetic compatibility

Tested under the following standards and regulations:
 EN 61326-1 (Use in industrial environment)
 NAMUR NE 21

Ambient conditions

Ambient temperature $-20 \text{ }^\circ\text{C} \dots +60 \text{ }^\circ\text{C} / +70 \text{ }^\circ\text{C}$
 (see instructions)
 Storage temperature $-40 \text{ }^\circ\text{C} \dots +80 \text{ }^\circ\text{C}$
 Relative humidity (no condensation) $\leq 95 \text{ }\%$

Connection diagram

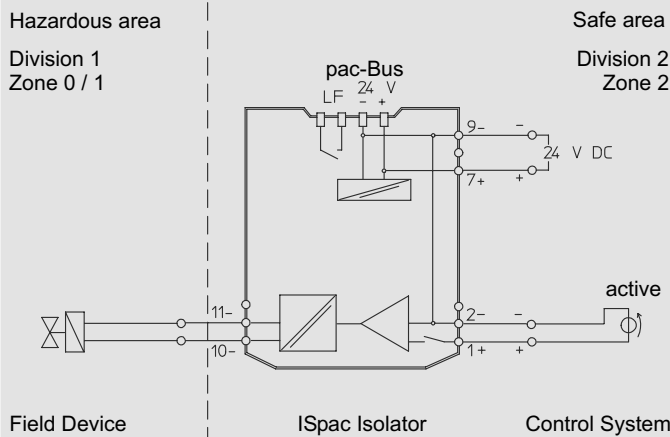

07758E02

Technical Data

Mechanical data	Screw terminals	Spring cage terminals	Insulation displacement connectors
Connection one wire			
- rigid	0.2 ... 2.5 mm ²	0.2 ... 2.5 mm ²	--
- flexible	0.2 ... 2.5 mm ²	0.2 ... 2.5 mm ²	0.5 ... 1 mm ²
- flexible, end covering sleeves (without / with plastic sleeving)	0.25 ... 2.5 mm ²	0.25 ... 2.5 mm ²	--
Connection two wires			
- rigid	0.2 ... 1 mm ²	--	--
- flexible	0.2 ... 1.5 mm ²	--	--
- flexible, end covering sleeves	0.25 ... 1 mm ²	0.5 ... 1 mm ²	--
Weight	approx. 160 g		
Mounting type	on DIN rail acc. to EN 50022 (NS35/15; NS35/7.5) or in pac-Carrier horizontal or vertical		
Mounting position	IP 30		
Casing protection class	IP 20		
Terminal protection class	PA 6.6		
Casing material	V0		
Fire protecting class (UL-94)	V0		

Dimension drawings (all dimensions in mm) - subject to alterations

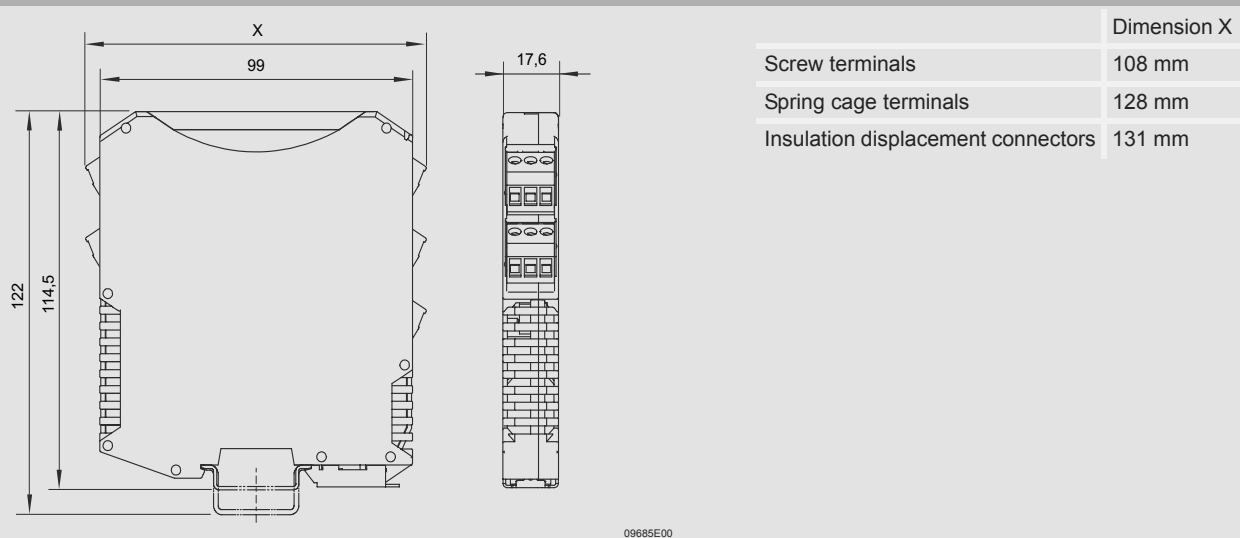

We reserve the right to make alterations to the technical data, weights, dimensions, designs and products available without notice. The illustrations cannot be considered binding.





09823E00

**Binary Output
with Line Fault Transparency
for $I_{max} = 45\text{ mA}$
Type 9175/10-14-12 LFT**

- Intrinsically safe output [Ex ia] IIC
- 1 channel
- Galvanic isolation between input and output
- Open-circuit and short-circuit monitoring (can be switched off)
- Line fault transparent (LFT): line fault signalling directly via output on PLC / DCS
- Installation possible in Zone 2
- For use up to SIL 2 (IEC 61508)

	Zones					
	0	1	2	20	21	22
Ex i interfaces	X	X	X	X	X	X
Installation in			X			X



Basic function: binary output, 1 channel.
The binary output is used for the intrinsically safe operation of Ex i solenoid valves or indicators.
The version 9175/10-14-12 LFT is characterised by line fault transparency. This function makes it possible to signal cable faults directly to the control level via the signal channel. The input for the binary output is high impedance in case of fault.

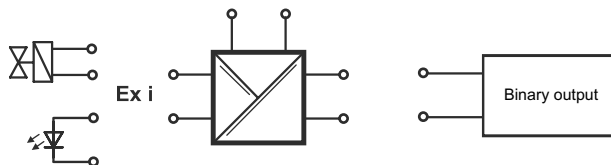

06256E02

Selection Table						
Version	Channels	No-load voltage U_A	Max. output current $I_{A \text{ max}}$	Internal resistance R_i	Connection type	Order number
Binary Output with Line Fault Transparency for $I_{max} = 45 \text{ mA}$ Type 9175/10-14-12 LFT	1	17.5 V	45 mA	130 Ω	Screw terminals	9175/10-14-12s
					Spring cage terminals	9175/10-14-12k

Technical Data													
Certificates	DMT 03 ATEX E 043 X												
Explosion protection	⊕ II 3 (1) G Ex nA nC [ia] IIC T4 and ⊕ II (1) D [Ex iaD]												
Installation	In Zone 2 and in the safe area												
Safe maximum values (CENELEC)	Max. voltage U_o 19.6 V Max. current I_o 150 mA Max. power P_o 732 mW Max. connectable capacitance IIC / IIB 235 nF / 1470 nF Max. connectable inductance IIC/ IIB 1.5 mH / 6 mH Internal capacitance C_i 1.1 nF Internal inductance L_i negligible Insulation voltage U_m 253 V												
Power supply	Nominal voltage U_N 24 V DC Voltage range 18 V ... 31.2 V Residual ripple within voltage range \leq 3.6 V _{pp} Indication LED green „PWR“ Polarity reversal protection yes Undervoltage monitoring yes (no faulty module / output states)												
Current consumption	Device draws its power from auxiliary power or signal cable as a function of its switching state. <table border="1"> <thead> <tr> <th>Switching state</th> <th>Auxiliary power Rated current I_N</th> <th>Signal input Rated current I_N</th> </tr> </thead> <tbody> <tr> <td>Input = Output</td> <td></td> <td></td> </tr> <tr> <td>OFF</td> <td>35 mA</td> <td>- -</td> </tr> <tr> <td>ON</td> <td>14 mA</td> <td>80 mA</td> </tr> </tbody> </table> Power consumption: 2.26 W Power loss: 1.73 W	Switching state	Auxiliary power Rated current I_N	Signal input Rated current I_N	Input = Output			OFF	35 mA	- -	ON	14 mA	80 mA
Switching state	Auxiliary power Rated current I_N	Signal input Rated current I_N											
Input = Output													
OFF	35 mA	- -											
ON	14 mA	80 mA											
Galvanic isolation	Test voltage under regulations EN 60079-11 Ex i output to input 1.5 kV AC Ex i output to power supply 1.5 kV AC Ex i output to error-contact 1.5 kV AC Test voltage under regulations EN 50178 Error-contact to power supply and inputs 350 V AC												
Input	Switching voltage according to EN 61131-2 Voltage for ON / OFF 18 V ... 31.2 V / 0 V ... 15 V Control current $<$ see current consumption table Input resistance R_i switching state OFF 3.5 k Ω												



Binary Output with Line Fault Transparency for $I_{max} = 45 \text{ mA}$ Type 9175/10-14-12 LFT



Technical Data

Ex i output

Output characteristic curves (at U_N ; $-20 \text{ }^\circ\text{C} \dots +60 \text{ }^\circ\text{C}$)
(more information see instructions)

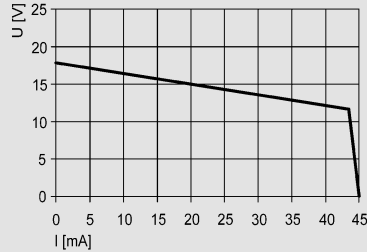

07759E00

Maximum values
each output

No-load voltage U_A 17.5 V
 Max. output current $I_{A \text{ max}}$ 45 mA
 Internal resistance R_i 130 Ω
 Residual ripple output $\leq 50 \text{ mV}$
 Switching delay OFF \leftrightarrow ON $\leq 1 \text{ ms}$
 Operating frequency $\leq 50 \text{ Hz}$
 Indication LED yellow „OUT“ each channel

Note

You may find a list of compatible Ex i solenoid valves on our homepage www.ispac.info.

Error detection Ex i output

Open-circuit $> 10 \text{ k}\Omega$
 Short-circuit (each output), at $23 \text{ }^\circ\text{C}$ $40 \text{ }\Omega \dots 80 \text{ }\Omega \pm 6 \text{ }\Omega / 10 \text{ K}$
 Settings (switch LF) activated / deactivated
 Error detection LED red „LF“ each channel
 Error messaging and power supply - contact on the signal input open in case of fault
 - pac-Bus, floating contact (30 V / 100 mA)

Electromagnetic compatibility

Tested under the following standards and regulations:
 EN 61326-1 (Use in industrial environment)
 NAMUR NE 21

Ambient conditions

Ambient temperature $-20 \text{ }^\circ\text{C} \dots +60 \text{ }^\circ\text{C} / +70 \text{ }^\circ\text{C}$
 (see instructions)
 Storage temperature $-40 \text{ }^\circ\text{C} \dots +80 \text{ }^\circ\text{C}$
 Relative humidity (no condensation) $\leq 95 \text{ }\%$

Connection diagram

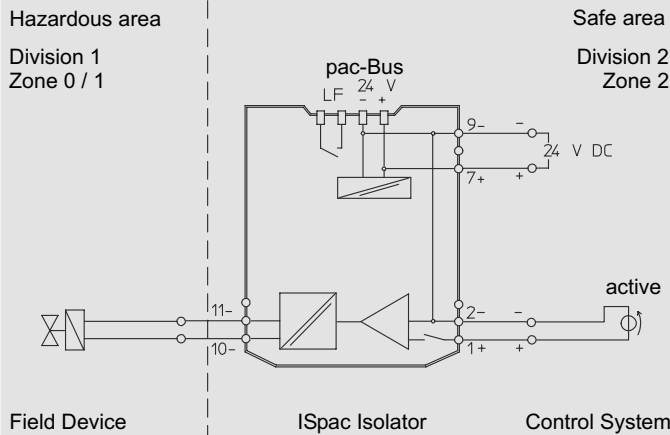

07758E02



Technical Data				
Mechanical data		Screw terminals	Spring cage terminals	Insulation displacement connectors
	Connection one wire			
	- rigid	0.2 ... 2.5 mm ²	0.2 ... 2.5 mm ²	--
	- flexible	0.2 ... 2.5 mm ²	0.2 ... 2.5 mm ²	0.5 ... 1 mm ²
	- flexible, end covering sleeves (without / with plastic sleeving)	0.25 ... 2.5 mm ²	0.25 ... 2.5 mm ²	--
	Connection two wires			
	- rigid	0.2 ... 1 mm ²	--	--
	- flexible	0.2 ... 1.5 mm ²	--	--
	- flexible, end covering sleeves	0.25 ... 1 mm ²	0.5 ... 1 mm ²	--
	Weight	approx. 160 g		
	Mounting type	on DIN rail acc. to EN 50022 (NS35/15; NS35/7.5) or in pac-Carrier horizontal or vertical		
	Mounting position	IP 30		
	Casing protection class	IP 20		
	Terminal protection class	PA 6.6		
	Casing material	V0		
	Fire protecting class (UL-94)	V0		

Dimension drawings (all dimensions in mm) - subject to alterations

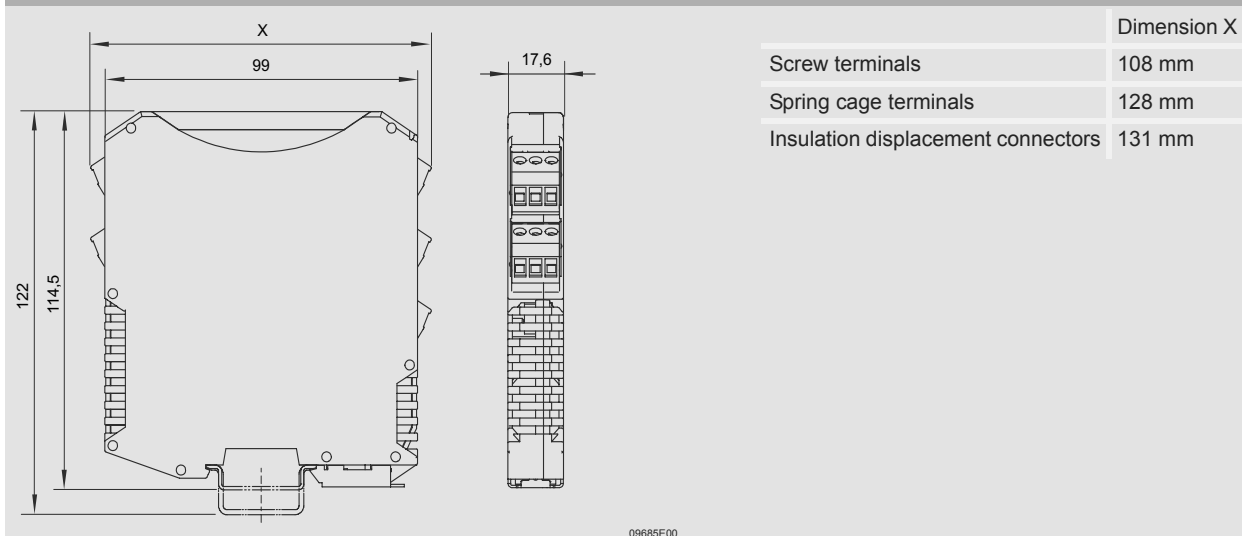

We reserve the right to make alterations to the technical data, weights, dimensions, designs and products available without notice. The illustrations cannot be considered binding.



09823E00

**Binary Output
with Line Fault Transparency
for $I_{max} = 35\text{ mA}$
Type 9175/10-16-12 LFT**

- Intrinsically safe output [Ex ia] IIC
- 1 channel
- Galvanic isolation between input and output
- Open-circuit and short-circuit monitoring (can be switched off)
- Line fault transparent (LFT): line fault signalling directly via output on PLC / DCS
- Installation possible in Zone 2
- For use up to SIL 2 (IEC 61508)

	Zones					
	0	1	2	20	21	22
Ex i interfaces	X	X	X	X	X	X
Installation in			X			X



Basic function: binary output, 1 channel.
The binary output is used for the intrinsically safe operation of Ex i solenoid valves or indicators.
The version 9175/10-16-12 LFT is characterised by line fault transparency. This function makes it possible to signal cable faults directly to the control level via the signal channel. The input for the binary output is high impedance in case of fault.

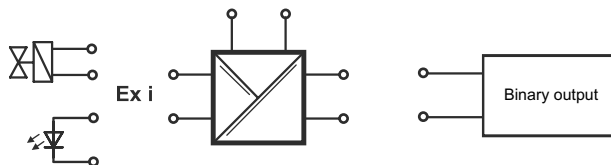

06256E02

Selection Table						
Version	Channels	No-load voltage U_A	Max. output current $I_{A \text{ max}}$	Internal resistance R_i	Connection type	Order number
Binary Output with Line Fault Transparency for $I_{max} = 35 \text{ mA}$ Type 9175/10-16-12 LFT	1	25 V	35 mA	250 Ω	Screw terminals	9175/10-16-12s
					Spring cage terminals	9175/10-16-12k

Technical Data													
Certificates	DMT 03 ATEX E 043 X												
Explosion protection	⊕ II 3 (1) G Ex nA nC [ia] IIC T4 and ⊕ II (1) D [Ex iaD]												
Installation	In Zone 2 and in the safe area												
Safe maximum values (CENELEC)	Max. voltage U_o 27.6 V Max. current I_o 110 mA Max. power P_o 760 mW Max. connectable capacitance IIC / IIB 85 nF / 667 nF Max. connectable inductance IIC/ IIB 1.2 mH / 9 mH Internal capacitance C_i 1.1 nF Internal inductance L_i negligible Insulation voltage U_m 253 V												
Power supply	Nominal voltage U_N 24 V DC Voltage range 18 V ... 31.2 V Residual ripple within voltage range \leq 3.6 V _{pp} Indication LED green „PWR“ Polarity reversal protection yes Undervoltage monitoring yes (no faulty module / output states)												
Current consumption	Device draws its power from auxiliary power or signal cable as a function of its switching state. <table border="1" style="margin-left: 20px;"> <thead> <tr> <th>Switching state</th> <th>Auxiliary power Rated current I_N</th> <th>Signal input Rated current I_N</th> </tr> </thead> <tbody> <tr> <td>Input = Output</td> <td></td> <td></td> </tr> <tr> <td>OFF</td> <td>40 mA</td> <td>- -</td> </tr> <tr> <td>ON</td> <td>14 mA</td> <td>90 mA</td> </tr> </tbody> </table> Power consumption: 2.5 W Power loss: 1.92 W	Switching state	Auxiliary power Rated current I_N	Signal input Rated current I_N	Input = Output			OFF	40 mA	- -	ON	14 mA	90 mA
Switching state	Auxiliary power Rated current I_N	Signal input Rated current I_N											
Input = Output													
OFF	40 mA	- -											
ON	14 mA	90 mA											
Galvanic isolation	Test voltage under regulations EN 60079-11 Ex i output to input 1.5 kV AC Ex i output to power supply 1.5 kV AC Ex i output to error-contact 1.5 kV AC Test voltage under regulations EN 50178 Error-contact to power supply and inputs 350 V AC												
Input	Switching voltage according to EN 61131-2 Voltage for ON / OFF 18 V ... 31.2 V / 0 V ... 15 V Control current $<$ see current consumption table Input resistance R_i switching state OFF 3.5 k Ω												



Binary Output with Line Fault Transparency for $I_{max} = 35 \text{ mA}$ Type 9175/10-16-12 LFT



Technical Data

Ex i output

Output characteristic curves (at U_N ; $-20 \text{ }^\circ\text{C} \dots +60 \text{ }^\circ\text{C}$)
(more information see instructions)

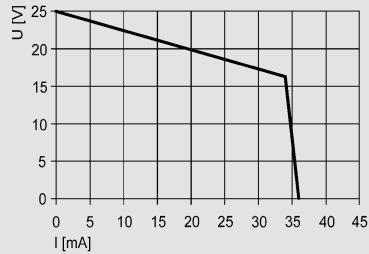

07761E00

Maximum values
each output

No-load voltage U_A 25 V
 Max. output current $I_{A \text{ max}}$ 35 mA
 Internal resistance R_i 250 Ω
 Residual ripple output $\leq 50 \text{ mV}$
 Switching delay OFF \leftrightarrow ON $\leq 1 \text{ ms}$
 Operating frequency $\leq 50 \text{ Hz}$
 Indication LED yellow „OUT“ each channel

Note

You may find a list of compatible Ex i solenoid valves on our homepage www.ispac.info.

Error detection Ex i output

Open-circuit (each output) $> 15 \text{ k}\Omega$
 Short-circuit (each output), at $23 \text{ }^\circ\text{C}$ $50 \text{ }\Omega \dots 90 \text{ }\Omega \pm 8 \text{ }\Omega / 10 \text{ K}$
 Settings (switch LF) activated / deactivated
 Error detection LED red „LF“ each channel
 Error messaging and power supply - contact on the signal input open in case of fault
 - pac-Bus, floating contact (30 V / 100 mA)

Electromagnetic compatibility

Tested under the following standards and regulations:
 EN 61326-1 (Use in industrial environment)
 NAMUR NE 21

Ambient conditions

Ambient temperature $-20 \text{ }^\circ\text{C} \dots +60 \text{ }^\circ\text{C} / +70 \text{ }^\circ\text{C}$
 (see instructions)
 Storage temperature $-40 \text{ }^\circ\text{C} \dots +80 \text{ }^\circ\text{C}$
 Relative humidity (no condensation) $\leq 95 \text{ }\%$

Connection diagram

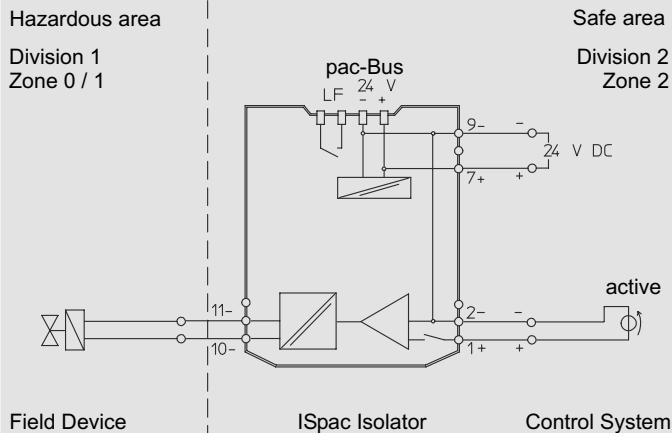

07758E02



Technical Data

Mechanical data	Screw terminals	Spring cage terminals	Insulation displacement connectors
Connection one wire			
- rigid	0.2 ... 2.5 mm ²	0.2 ... 2.5 mm ²	--
- flexible	0.2 ... 2.5 mm ²	0.2 ... 2.5 mm ²	0.5 ... 1 mm ²
- flexible, end covering sleeves (without / with plastic sleeving)	0.25 ... 2.5 mm ²	0.25 ... 2.5 mm ²	--
Connection two wires			
- rigid	0.2 ... 1 mm ²	--	--
- flexible	0.2 ... 1.5 mm ²	--	--
- flexible, end covering sleeves	0.25 ... 1 mm ²	0.5 ... 1 mm ²	--
Weight	approx. 160 g		
Mounting type	on DIN rail acc. to EN 50022 (NS35/15; NS35/7.5) or in pac-Carrier horizontal or vertical		
Mounting position	IP 30		
Casing protection class	IP 20		
Terminal protection class	PA 6.6		
Casing material	V0		
Fire protecting class (UL-94)	V0		

Dimension drawings (all dimensions in mm) - subject to alterations

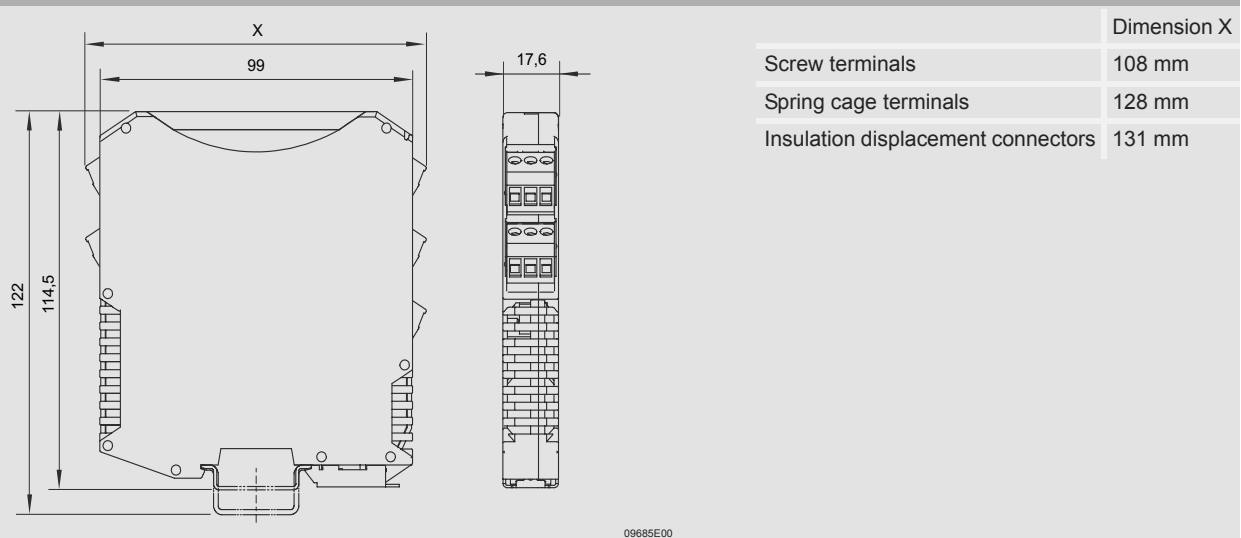

We reserve the right to make alterations to the technical data, weights, dimensions, designs and products available without notice. The illustrations cannot be considered binding.



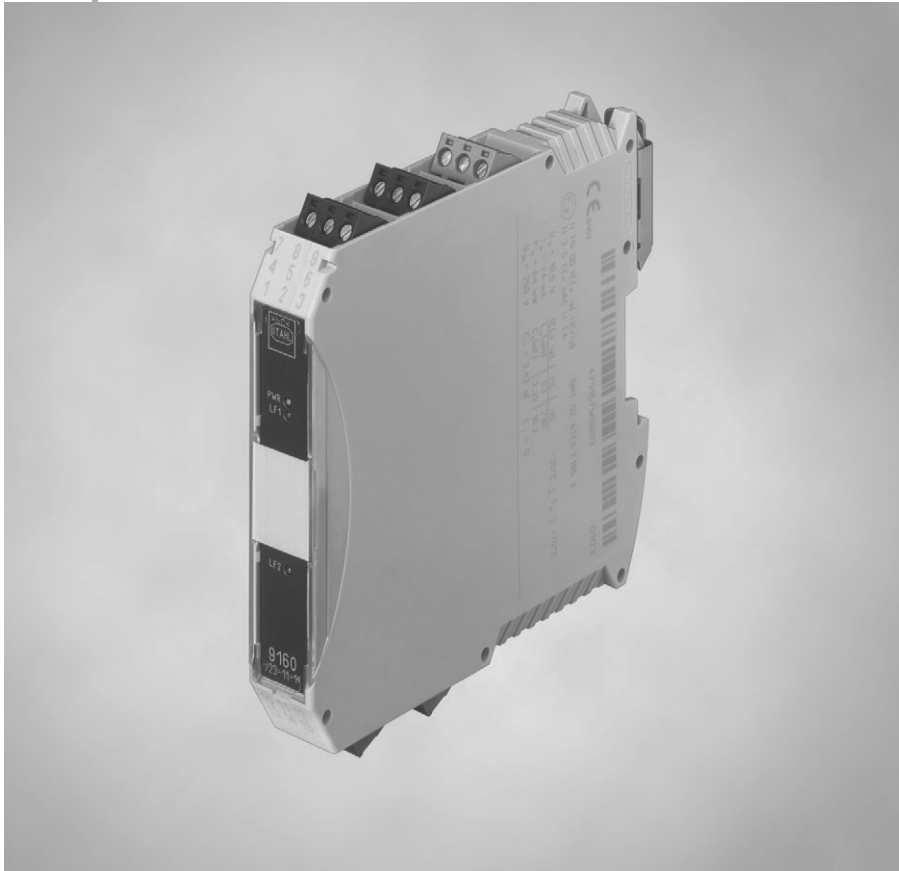

09738E00

**Transmitter Supply Unit
with Output 0/4 mA ... 20 mA
Passive with HART
(Field Circuit Ex i)
Type 9160/..-10-11**

- Passive output
- Suitable for 2-, 3-wire transmitter, 2-wire HART transmitter and mA-sources
- Intrinsically safe input [Ex ia] IIC
- 1 and 2 channels
- Galvanic isolation between input, output and power supply
- Open-circuit and short-circuit monitoring and messaging for input and output (can be switched off)
- Installation possible in Zone 2 and Div. 2
- Can be used up to SIL 2 (IEC 61508)

STAHL

Basic function: analog input 0/4 mA ... 20 mA, 1 and 2 channels. The transmitter supply units are used for intrinsically safe operation of 2- and 3- wire transmitters or for connection to intrinsically safe mA-sources.

The 2- and 3-wire transmitters are supplied with power from the transmitter supply unit.

For 2-wire transmitters the isolators transfer the HART communication signal bidirectionally.

	Zones					
	0	1	2	20	21	22
Ex i interfaces	X	X	X	X	X	X
Installation in			X			X

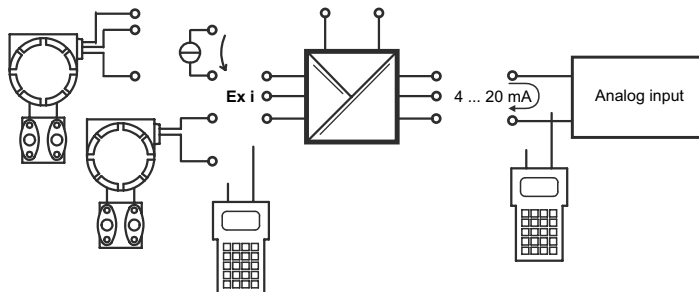

09363E02

Selection Table							
Version	Channels	Input	Output A	Output B	Connection type	Order number	
Transmitter supply unit Type 9160, field circuit Ex i Passive output	1	0/4 mA ... 20 mA with HART	passive with HART	--	Screw terminals	9160/13-10-11s	
					Spring cage terminals	9160/13-10-11k	
					passive	Screw terminals	9160/19-10-11s
					Spring cage terminals	9160/19-10-11k	
	2	0/4 mA ... 20 mA with HART	passive with HART	passive with HART	Screw terminals	9160/23-10-11s	
					Spring cage terminals	9160/23-10-11k	

Technical Data																							
Certificates	DMT 03 ATEX E 010 X																						
Other certificates	USA (FM, UL), Canada (CSA), Russia (CTB), Belarus (Promatomnadzor), Brazil (UL do Brasil), Ukraine (ISCVE), Shipping (DNV)																						
Explosion protection	Ⓜ II 3 (1) G Ex nA nC [ia] IIC T4 Ⓜ II (1) D [Ex iaD]																						
Installation	In Zone 2, Div. 2 and in the safe area																						
Safe maximum values (GENELEC)	<table style="width: 100%; border: none;"> <tr><td>Max. voltage U_o</td><td>27 V</td></tr> <tr><td>Max. current I_o</td><td>88 mA</td></tr> <tr><td>Max. power P_o</td><td>576 mW</td></tr> <tr><td>Max. connectable capacitance C_o for IIC / IIB</td><td>90 nF / 705 nF</td></tr> <tr><td>Max. connectable inductance L_o for IIC / IIB</td><td>2.3 mH / 14 mH</td></tr> <tr><td>Internal capacitance C_i and inductance L_i</td><td>negligible</td></tr> <tr><td>Insulation voltage U_m</td><td>250 V</td></tr> </table> When connecting mA sources: <table style="width: 100%; border: none;"> <tr><td>Max. output voltage U_o</td><td>4.1 V</td></tr> <tr><td>Max. connectable voltage U_i</td><td>30 V</td></tr> <tr><td>Max. connectable current I_i</td><td>100 mA</td></tr> <tr><td>Internal capacitance C_i and inductance L_i</td><td>negligible</td></tr> </table> Further information and combinations of values, see certification.	Max. voltage U_o	27 V	Max. current I_o	88 mA	Max. power P_o	576 mW	Max. connectable capacitance C_o for IIC / IIB	90 nF / 705 nF	Max. connectable inductance L_o for IIC / IIB	2.3 mH / 14 mH	Internal capacitance C_i and inductance L_i	negligible	Insulation voltage U_m	250 V	Max. output voltage U_o	4.1 V	Max. connectable voltage U_i	30 V	Max. connectable current I_i	100 mA	Internal capacitance C_i and inductance L_i	negligible
Max. voltage U_o	27 V																						
Max. current I_o	88 mA																						
Max. power P_o	576 mW																						
Max. connectable capacitance C_o for IIC / IIB	90 nF / 705 nF																						
Max. connectable inductance L_o for IIC / IIB	2.3 mH / 14 mH																						
Internal capacitance C_i and inductance L_i	negligible																						
Insulation voltage U_m	250 V																						
Max. output voltage U_o	4.1 V																						
Max. connectable voltage U_i	30 V																						
Max. connectable current I_i	100 mA																						
Internal capacitance C_i and inductance L_i	negligible																						
Power supply	<table style="width: 100%; border: none;"> <tr><td>Nominal voltage U_N</td><td>24 V DC</td></tr> <tr><td>Voltage range</td><td>18 V ... 31.2 V</td></tr> <tr><td>Residual ripple within voltage range</td><td>≤ 3.6 V_{pp}</td></tr> <tr><td>Nominal current (U_N, 20 mA) 1 / 2 channels</td><td>70 mA / 125 mA</td></tr> <tr><td>Power consumption (U_N, 20 mA) 1 / 2 channels</td><td>1.7 W / 3.0 W</td></tr> <tr><td>Power losses (at U_N, $R_L = 250 \Omega$) 1 / 2 channels</td><td>1.3 W / 2.2 W</td></tr> <tr><td>Indication</td><td>LED green „PWR“</td></tr> <tr><td>Polarity reversal protection</td><td>yes</td></tr> <tr><td>Undervoltage monitoring</td><td>yes (no faulty module / output states)</td></tr> </table>	Nominal voltage U_N	24 V DC	Voltage range	18 V ... 31.2 V	Residual ripple within voltage range	≤ 3.6 V _{pp}	Nominal current (U_N , 20 mA) 1 / 2 channels	70 mA / 125 mA	Power consumption (U_N , 20 mA) 1 / 2 channels	1.7 W / 3.0 W	Power losses (at U_N , $R_L = 250 \Omega$) 1 / 2 channels	1.3 W / 2.2 W	Indication	LED green „PWR“	Polarity reversal protection	yes	Undervoltage monitoring	yes (no faulty module / output states)				
Nominal voltage U_N	24 V DC																						
Voltage range	18 V ... 31.2 V																						
Residual ripple within voltage range	≤ 3.6 V _{pp}																						
Nominal current (U_N , 20 mA) 1 / 2 channels	70 mA / 125 mA																						
Power consumption (U_N , 20 mA) 1 / 2 channels	1.7 W / 3.0 W																						
Power losses (at U_N , $R_L = 250 \Omega$) 1 / 2 channels	1.3 W / 2.2 W																						
Indication	LED green „PWR“																						
Polarity reversal protection	yes																						
Undervoltage monitoring	yes (no faulty module / output states)																						
Galvanic isolation	<table style="width: 100%; border: none;"> <tr><td>Test voltage under regulations EN 60079-11</td><td></td></tr> <tr><td>Ex i input to output</td><td>1.5 kV AC</td></tr> <tr><td>Ex i input to power supply</td><td>1.5 kV AC</td></tr> <tr><td>Ex i input to Error-contact</td><td>1.5 kV AC</td></tr> <tr><td>Ex i inputs to each other</td><td>500 V AC</td></tr> <tr><td>Test voltage under regulations EN 50178</td><td></td></tr> <tr><td>Output to power supply</td><td>350 V AC</td></tr> <tr><td>Outputs to each other</td><td>350 V AC</td></tr> <tr><td>Error-contact to power supply and outputs</td><td>350 V AC</td></tr> </table>	Test voltage under regulations EN 60079-11		Ex i input to output	1.5 kV AC	Ex i input to power supply	1.5 kV AC	Ex i input to Error-contact	1.5 kV AC	Ex i inputs to each other	500 V AC	Test voltage under regulations EN 50178		Output to power supply	350 V AC	Outputs to each other	350 V AC	Error-contact to power supply and outputs	350 V AC				
Test voltage under regulations EN 60079-11																							
Ex i input to output	1.5 kV AC																						
Ex i input to power supply	1.5 kV AC																						
Ex i input to Error-contact	1.5 kV AC																						
Ex i inputs to each other	500 V AC																						
Test voltage under regulations EN 50178																							
Output to power supply	350 V AC																						
Outputs to each other	350 V AC																						
Error-contact to power supply and outputs	350 V AC																						



Transmitter Supply Unit with Output 0/4 mA ... 20 mA Passive with HART (Field Circuit Ex i) Type 9160/..-10-11



Technical Data		
Ex i Input	Input signal	0/4 mA ... 20 mA with HART
	Function area	0 mA ... 24 mA
	Max. input current for mA sources	50 mA
	Transmitter supply voltage	≥ 16 V at 20 mA (for 2-, 3-wire)
	Supply voltage residual ripple	≤ 25 mV _{eff}
	No-load voltage	≤ 26 V
	Short-circuit current	≤ 35 mA
	Input resistance (AC-Impedance HART)	≈ 500 Ω
	Input resistance for mA sources	30 Ω
	Communication signal (at 2-wire transmitter)	HART transmission bi-directional, 0.5 kHz ... 30 kHz
	Output	Output signal
- Type variant 9160/3-10-11.		Current sink up, max. 30 V with HART
- Type variant 9160/19-10-11.		output A: Current sink up, max. 30 V with HART output B: Current sink up, max. 30 V without HART
Load resistance R _L at 9160/..-10-11.		0 Ω bei 5 V ... 15 V 500 Ω bei 24 V 800 Ω bei 30 V
Residual ripple		≤ 40 μA _{eff}
No-load voltage		≤ 15.5 V
Communication signal (at 9160/19 only output A)		HART transmission bi-directionale 0.5 kHz ... 30 kHz
Response time (10 % ... 90 %)	≤ 25 ms	
Error detection Ex i Input	Open-circuit	< 2 mA
	Short-circuit	> 22 mA
	Behaviour of output	= Input signal
	Output current at I _E = 0	I _A = 0 mA
Error detection output	Open-circuit	< 2 mA
Error messaging Ex i Input / Output	Settings (switch LF)	activated / deactivated
	Error detection	LED red „LF“ each channel
	Error messaging and power supply failure	- Contact (30 V, 100 mA), closed to ground in case of error - pac-Bus, floating contact (30 V, 100 mA)
Error limits	Accuracy, typical data expressed as % of calibrated span at U _N , 23 °C	
	Linearity error	≤ 0.1 %
	Offset error	≤ 0.1 %
	Temperature influence	≤ 0.1 % / 10 K
	Power supply effect within voltage range	≤ 0.01 %
	Load resistance effect	≤ 0.02 %
Cross-talk channel 1 / channel 2	≤ 0.01 %	
Electromagnetic compatibility	Tested under the following standards and regulations: EN 61326-1 Use in industrial environment	
Ambient conditions	Ambient temperature	- 20 °C ... + 60 °C / + 70 °C (see instructions)
	Storage temperature	- 40 °C ... + 80 °C
	Relative humidity (no condensation)	≤ 95 %

Technical Data

Mechanical data

	Screw terminals	Spring cage terminals	Insulation displacement connectors
Connection one wire			
- rigid	0.2 ... 2.5 mm ²	0.2 ... 2.5 mm ²	--
- flexible	0.2 ... 2.5 mm ²	0.2 ... 2.5 mm ²	0.5 ... 1 mm ²
- flexible, end covering sleeves (without / with plastic sleeving)	0.25 ... 2.5 mm ²	0.25 ... 2.5 mm ²	--
Connection two wires			
- rigid	0.2 ... 1 mm ²	--	--
- flexible	0.2 ... 1.5 mm ²	--	--
- flexible, end covering sleeves	0.25 ... 1 mm ²	0.5 ... 1 mm ²	--
Weight	approx. 160 g		
Mounting type	on DIN rail acc. to EN 50022 (NS35/15; NS35/7.5) or in pac-Carrier horizontal or vertical		
Mounting position	IP 30		
Casing protection class	IP 20		
Terminal protection class	PA 6.6		
Casing material	V0		
Fire protecting class (UL-94)	V0		

Connection diagram

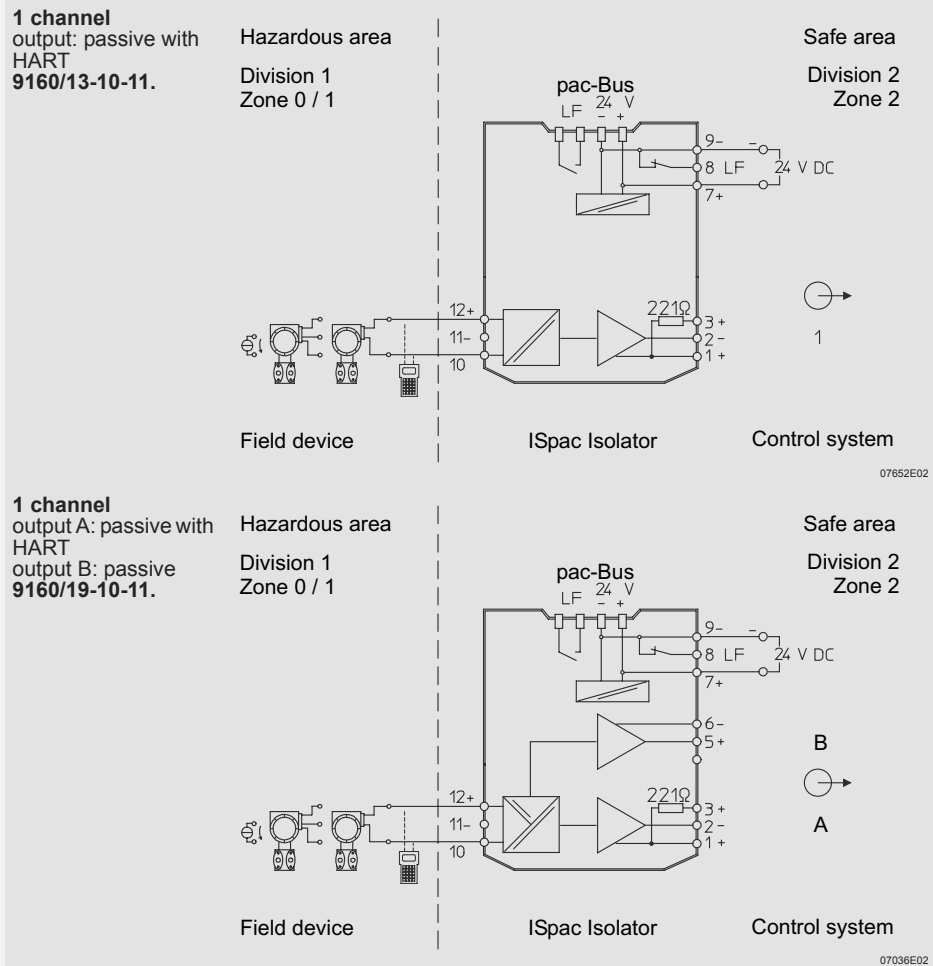

Transmitter Supply Unit with Output 0/4 mA ... 20 mA Passive with HART (Field Circuit Ex i) Type 9160/..-10-11



Technical Data

Connection diagram

2 channels
outputs: passive with HART
9160/23-10-11.

Hazardous area
Division 1
Zone 0 / 1

Safe area
Division 2
Zone 2

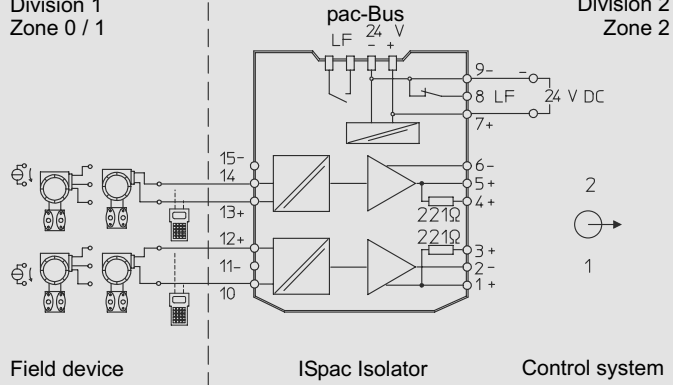

07035E02

Configuration output

	9160/3-10-11.	9160/19-10-11.
Channel 2 / Output B	<p>09741E00</p>	<p>04813E00</p>
Channel 1 / Output A	<p>09743E00</p>	<p>09743E00</p>

Dimension drawings (all dimensions in mm) - subject to alterations

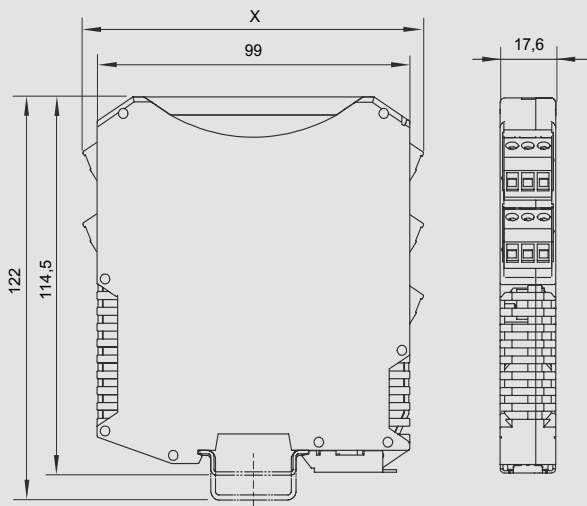

09685E00

	Dimension X
Screw terminals	108 mm
Spring cage terminals	128 mm
Insulation displacement connectors	131 mm

We reserve the right to make alterations to the technical data, weights, dimensions, designs and products available without notice. The illustrations cannot be considered binding.



STAHL



09735E00

Isolating Repeater (Field Circuit Ex i) Type 9165 Rev. C

- For HART output signals
0/4 mA ... 20 mA
- Intrinsically safe output [Ex ia] IIC
- 1 and 2 channels
- Galvanic isolation between input, output and power supply
- Open circuit / short-circuit monitoring and messaging (can be switched off)
- Installation possible in Zone 2
- For use up to SIL 2 (IEC 61508)

	Zones					
	0	1	2	20	21	22
Ex i interfaces	X	X	X	X	X	X
Installation in			X			X



Basic function: analog output 0/4 mA ... 20 mA with HART, 1 and 2 channels.

These isolating repeaters are used in the intrinsically safe operation of control valves, i/p-converters or indicators. Operation of intrinsically safe HART-valves is possible, too. The isolators transmit the HART communication signal bidirectionally.

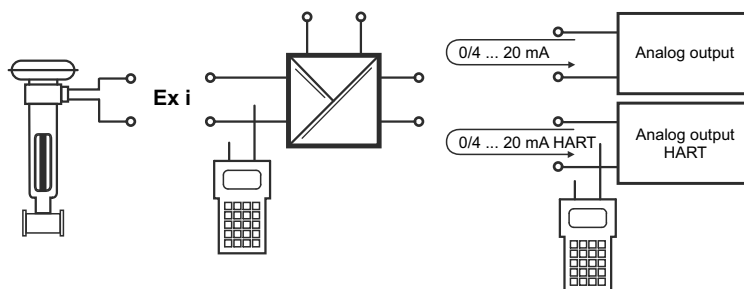

09461E02

Technical Data			
Fault limits	Accuracy, typical data expressed as % of calibrated span at U_N , 23 °C		
	Linearity fault	≤	0.05 %
	Offset fault	≤	0.05 %
	Temperature influence	≤	0.05 % / 10 K
	Power supply effect within voltage range	≤	0.01 %
	Influence of load resistance	≤	0.02 %
	Cross-talk channel 1 / channel 2	≤	0.01 %
Electromagnetic compatibility			
Ambient conditions			
Connection diagram			
Mechanical data		Screw terminals	Spring cage terminals
	Connection single-wire		
	- rigid	0.2 mm ² ... 2.5 mm ²	0.2 mm ² ... 2.5 mm ²
	- flexible	0.2 mm ² ... 2.5 mm ²	0.2 mm ² ... 2.5 mm ²
	- flexible, end covering sleeves (without / with plastic sleeving)	0.25 mm ² ... 2.5 mm ²	0.25 mm ² ... 2.5 mm ²
	Connection two wires		
	- rigid	0.2 mm ² ... 1 mm ²	--
	- flexible	0.2 mm ² ... 1.5 mm ²	--
	- flexible, end covering sleeves	0.25 mm ² ... 1 mm ²	0.5 mm ² ... 1 mm ²
	Weight	approx. 160 g	
Assembly type	on DIN rail (NS35/15; NS35/7.5) or in pac-Carrier		
Installation position	Vertical or horizontal		
Enclosure Ingress Protection	IP30		
Terminal Ingress Protection	IP20		
Enclosure material	PA 6.6		
Fire protection class (UL 94)	V0		

Dimensional Drawing (All Dimensions in mm) - Subject to Alterations

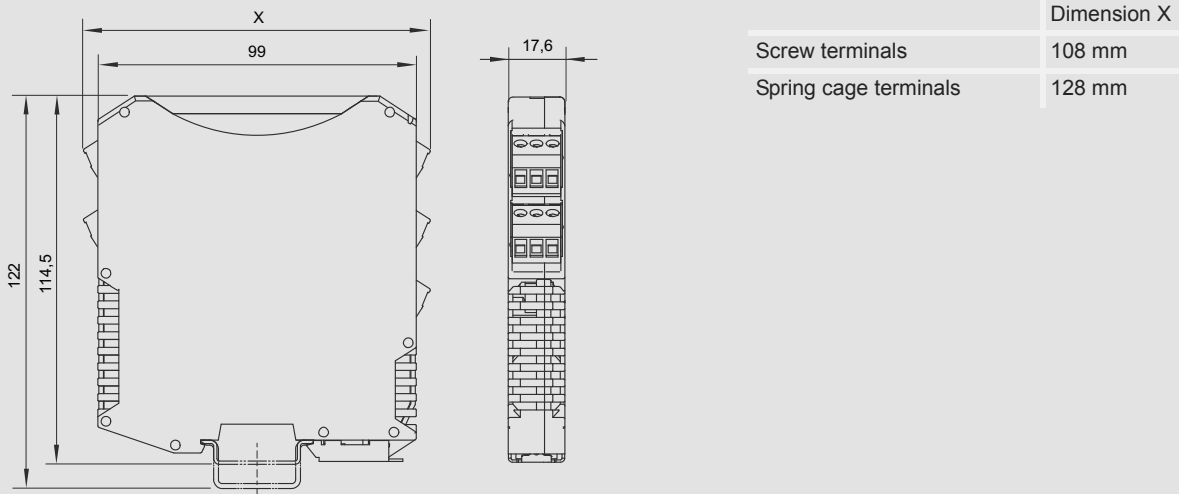

We reserve the right to make alterations to the technical data, weights, dimensions, designs and products available without notice. The illustrations cannot be considered binding.



Notes:





R. STAHL Schaltgeräte GmbH
Am Bahnhof 30, D-74638 Waldenburg, Germany
Telefon +49 7942 943-0
Telefax +49 7942 943-4333
E-Mail: info.ex@stahl.de
Internet: <http://www.stahl.de>

S – EG / EP – 9195 – 06 – en – 03 / 2010