

MULTIBOX 25

Made of hot-pressed glassfibre reinforced polyester
 Two-part construction, equipment can be installed in either the shallow or deep part.
 Stackable design for space saving storage and transport
 Approved by „Lloyds of Germany“
 Hardly inflammable and self-extinguishing
 4 mounting elements in stainless steel

- Colour: light grey, RAL 7032
- UV-resistant
- Protection class IP65 / Nema 4X
- Neoprene seal
- Weight approx 6kg

Dimensions (approx) H x B x T = 485 x 385 x 240 mm

Heat transition Coefficient K	without window	with window
without Insulation	2,5 W/K	2,9 W/K
arctic.....	0,9 W/K	1,3 W/K

Importend accessories see catalogue

Standard

SV 4 clasps in stainless steel

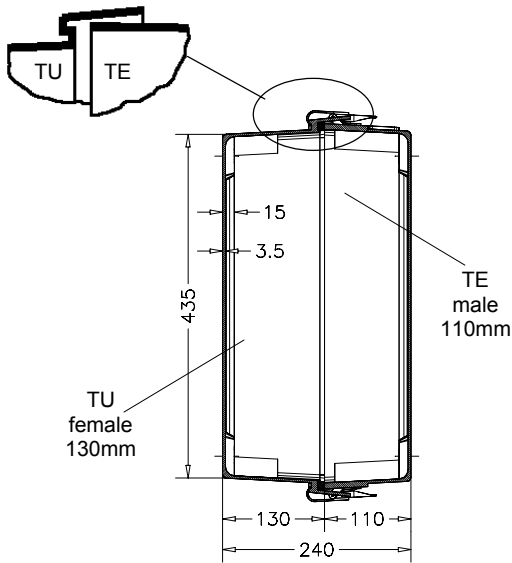

Optional designs

- SE** 2 hinges and 2 clasps in stainless steel
- DF** lid propstay in galvanized steel, fitted
- DFVA** lid propstay in stainless steel, fitted
- DFGF** lid propstay, gas compression spring

- FA** acrylic glass window
 - FS** safety glass window
 - STA** hinged door of acrylic glass
- } mounting in TE TU

arctic Insulation

PU-foam, not stackable

- arctic-PP** Polypropylen lining (standard)
- arctic-Alu** Alu-foil lining (for GO)
- GO** antistatic to avoid electrostatic charges according to EN IEC 60079-0
- (Ex)p** preparation for pressurization acc. to EN 50016, PTB-No. Ex-84/1118X

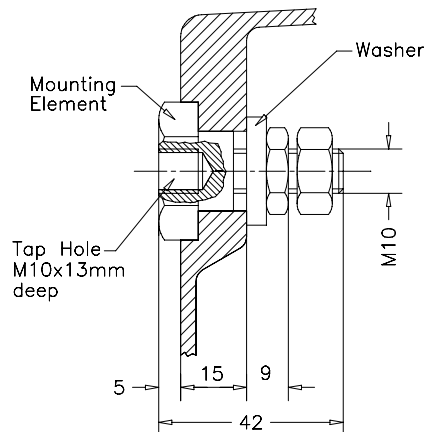
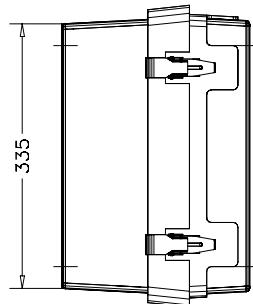
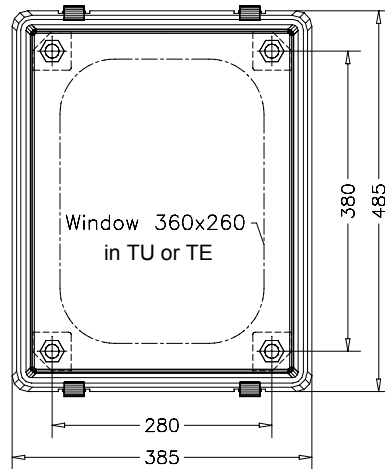

Ordering example.: 25 SE FS TE – arctic-Alu