

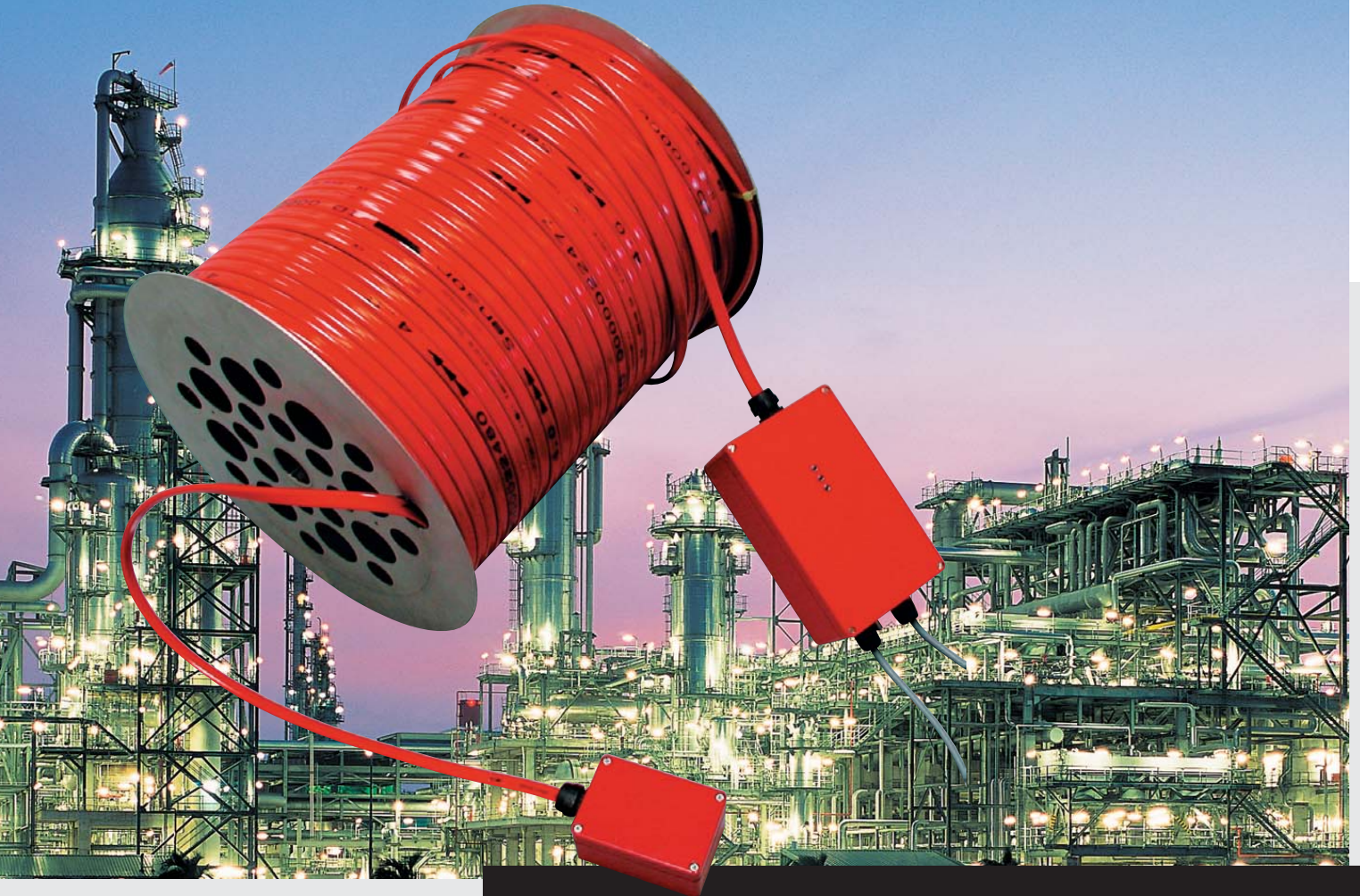

NOW also for use in hazardous areas!



# *RedGuard*®

**RedGuard® Temperature Monitoring System**

# RedGuard® Temperature Monitoring System

Plant safety and reliability, accident prevention and process and product quality are today the top themes in industrial plants. In every respect, the processes must assure the ultimate in safety and reliability. Safety measures are top priorities particularly in plants with an increased danger potential, such as for example in the chemicals and pharmaceutical industries, in the area of oil & gas, in power stations, in the fodder industry and of course in mining.

Temperature monitoring is a highly charged issue. Overheating, fires and leakages can cause immense damage. The earlier the risk is recognised and can be localised, the higher the chance of preventing damage to people, machinery and the environment.

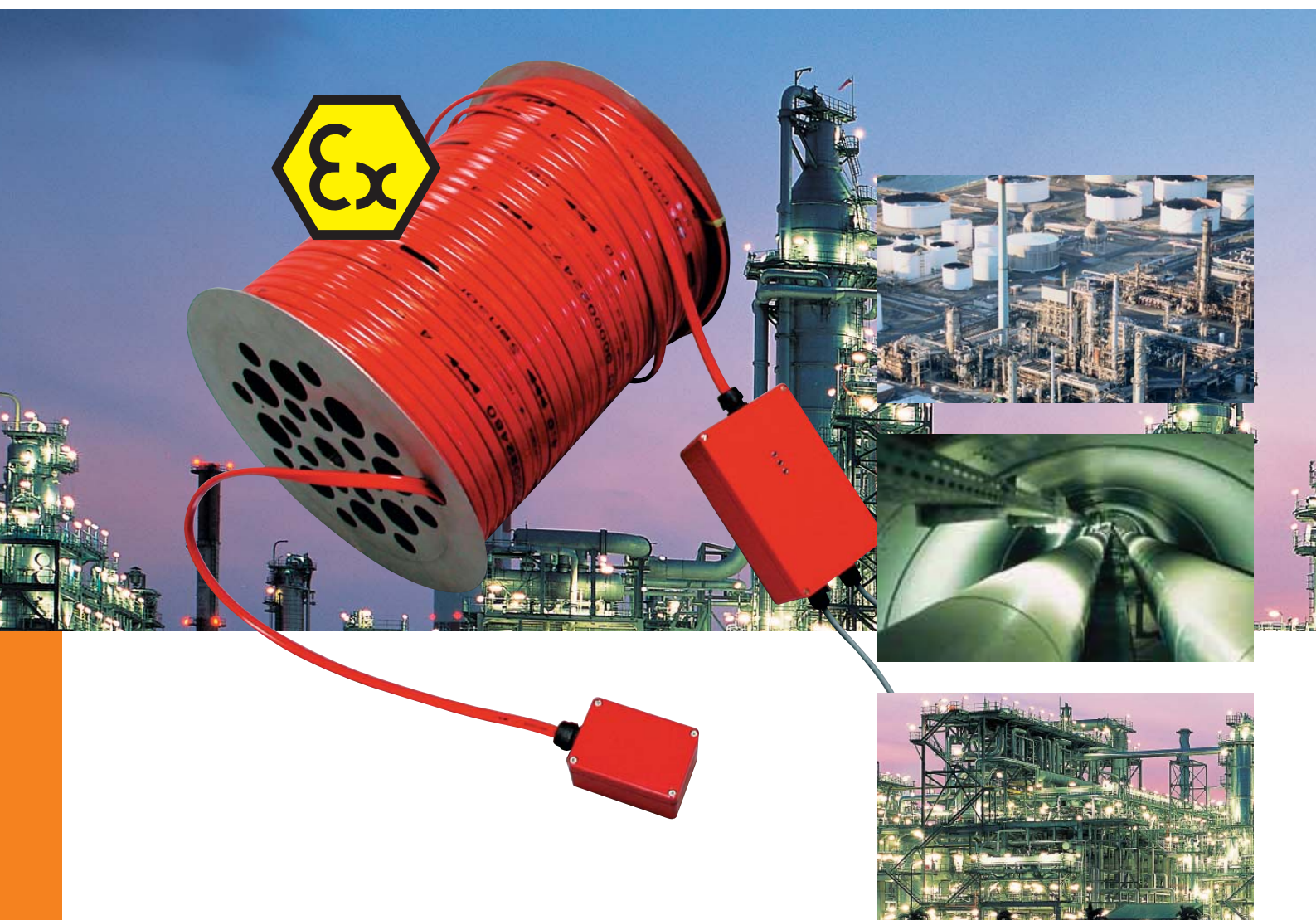

## **RedGuard® Temperature Monitoring System**

The patented RedGuard® Temperature Monitoring System offers an easy and safe temperature monitoring solution for hazardous areas too.

The RedGuard® system design is simple and consists in principle of a sensor cable with integrated sensors and a processor unit. The processor unit registers and analyses the temperature readings values from up to 250 temperature sensors. Whenever the preset threshold readings are exceeded, the system generates an alarm.

### **Applications and areas of use**

- Monitoring of leakage and fire  
Operating range: energy tunnels and cable ducts
- Monitoring of temperature in pipes and containers  
Operating range: process industry, chemicals, pharmaceuticals, oil and gas
- Leakage, temperature and fire monitoring  
Operating range: refilling stations and tank farms for flammable liquids

### **Features of the RedGuard® system**

- Sensor spacing freely selectable (2 m, 4 m, 7 m, 10 m, 20 m)
- Integrated sensor & control system with universal interfaces
- Wide measuring temperature range (-55 °C to +125 °C)
- Short system response time (< 5 seconds)
- Long-time stability, self-monitoring, maintenance-free
- Possibility of integrating sensors for other parameters
- Simple project planning, freely programmable system reaction

## System design/components

- **Sensor cable** (SD/polyurethane or HD/fluoropolymer)
- **Connection Filter Module (CFM)**  
for connecting the input lead (CCA) to the sensor cable or connecting two sensor cable segments
- **Protection Filter Module (PFM)** protects sensors against undue voltages
- **Cable Termination Module (CTM)** to terminate the sensor cable
- **Processor unit** (SSP or SRG)
- **Generic Sensor Interface (GSI)** to connect external sensors
- **Relay Control Unit (RCU)** for controlling a further 32 relays to localize the alarm

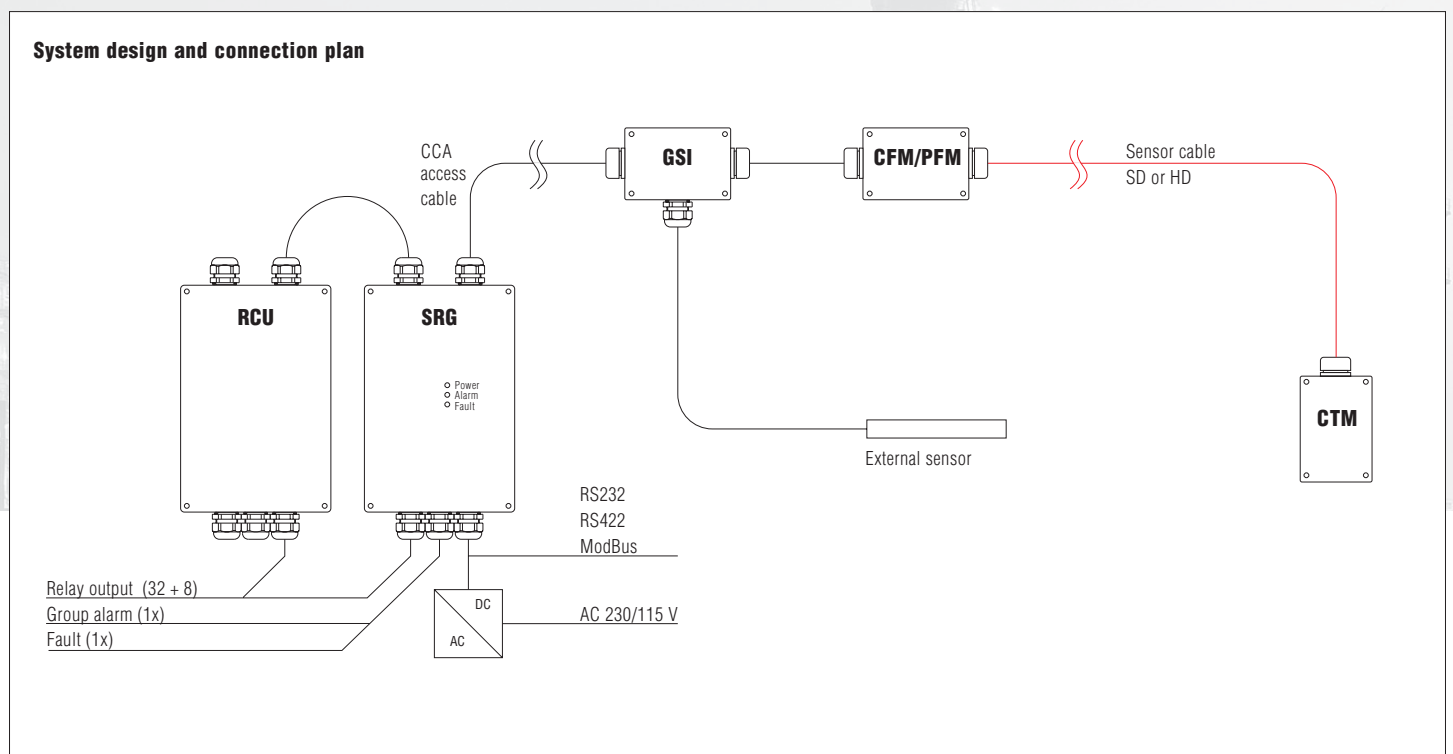

## Function

### **Analysis of sensor data in real time**

The processor unit (SSP/SRG) scans the sensor cable and converts the analog signals into temperature measurement values.

4 threshold values can be defined for each sensor. A further 4 threshold values are freely settable over the complete length of the sensor cable. The sensor data and operating states are scanned in real time on the interfaces. This allows unusual states to be recognised immediately and forwarded or for the alarm to be triggered.

The complete system is programmed with the RGCC configuration software. The TMON visualisation software is available for the visual presentation of the temperature profile on PC.

### **Reliable alarm and fault relay output**

The alarm can be programmed for latching or pulse mode. The relay contacts are controlled by means of the software or by hardware monitoring (watchdog). The yellow light diode is coupled with the fault and the red light diode is coupled with the alarm relay.

### **Storage of the temperature readings**

All events are stored in a cyclic event logger. The event logger can be scanned through the serial interface.

Furthermore, all events and also the sensor readings can be saved to a plug-in flash memory. This can be read by an external computer. It contains enough storage space to collect and file data for months.

The system can be operated on its own or in combination with superordinate systems through serial interfaces.

### **Integration of external sensors**

Additional external sensors can be connected through a sensor interface (GSI).

If external sensor technology is connected through the GSI, the readings are transmitted with 10-bit resolution and converted into the respective units.

## Sensor cable

The sensor cable contains the entire electronics for measuring temperature, addressing the sensors and transmitting data to the processor unit. The sensor spacings are selectable: 2, 4, 7, 10 or 20 m. One unit can monitor up to 2000 metres of sensor cable.

### Design

The sensor cable consists of an 8-strand flat cable: 2 as redundant conductors for ground, 2 for supply voltage, 2 for data transmission and 2 for addressing. The flat cable is protected by two additional covers. The inner thermoplastic elastomer jacket serves as a barrier to humidity and the outer polyurethane or fluoropolymer jacket is optimised for mechanical and chemical resistance.



### Technical data

Measuring temperature range	-55 °C to +125 °C
Precision	+/-2 °C
Sensitivity	+/-0.05 °C
Calibration	Calibration data are supplied for each sensor
Sampling rate	up to 100 sensors per second
Response time	< 5 seconds

### Electrical data

Current consumption	to 140 µA per sensor (typical)
---------------------	--------------------------------

### Mechanical data

Operating temperature range	SD (Polyurethane): -40 °C to +85 °C, short-time up to +125 °C HD (Fluoropolymer): -55 °C to +125 °C
-----------------------------	--

Dimensions	6.4 x 13.2 mm
Material	Outer jacket of polyurethane, red Outer jacket of fluoropolymer, grey
Protection class	IP 68
Installation temperature	+5 °C to +45 °C
Bending radius	50 mm between sensors and 200 mm in sensor positions
Pulling strength	500 N during installation, 0N during operation
Fastening	Special mounting clamps for horizontal and vertical mounting (optimum mounting spacing 1 m)
Labelling	Sensor position, serial number, spacing, marking
Connection technology	insulation displacement connection with standard tools, 8-pole connectors, grid spacing: 1.27 mm
Max. length of the sensor cable	500 m per cable reel

Selection chart Sensor cable	
Sensorspacing	Code no.
2 m	<b>020</b>
4 m	<b>040</b>
7 m	<b>070</b>
10 m	<b>100</b>
20 m	<b>200</b>

### Sensor cable SD

Polyurethane outer jacket

➔ CTS ROPURROBT1

### Sensor cable HD

Fluoropolymer outer jacket

➔ CTS ROFLUGRBT1

### Complete order no.

Please enter code number.

## Processor unit

The measurement values are evaluated in the SSP/SRG processor unit. The processor unit controls data communication, stores events and monitors the proper functioning of the system. The temperature sensors in the sensor cable are actuated sequentially, the measurements are read into a ring memory and analysed after every interrogation cycle.

Depending on the user configuration of the RedGuard® Software, the control unit can output an alarm on an LED and a relay and/or per data interface. The alarm events are configured by means of four threshold temperature values (min./max. absolute temperature or temperature gradient). These threshold readings can be set for the entire system and for each individual sensor. An algorithm allows configuration of up to 25 reaction patterns.



### Technical data

Data memory	cyclical event logger for the last 100 events, plug-in flash memory for several months, depending on memory capacity and sampling interval
Sampling rate	up to 100 sensors per second
Response time	< 5 seconds
Interface	RS232/RS422 or ModBus

### Electrical data

Supply voltage	12/24 V
Output voltage relay	9 to 50 V
Switching capacity relay	max. 20 watts; normally closed or normally open contact
Display	LED green: supply; LED red: alarm; LED yellow: fault

### Mechanical data

Operating temperature range	-25 °C to +65 °C
Dimensions	<b>SSP</b> 200 x 150 x 74 mm (without cable entry) <b>SRG</b> 241 x 160 x 90 mm (without cable entry) <b>RCU</b> 241 x 160 x 90 mm (without cable entry)
Material	ABS
Protection class	IP 67
Connection technology	insulation displacement connection technology with standard tools, 8-pole connectors, grid spacing: 1.27 mm

### Selection chart Processor unit

Description processor unit	Order no.
with 2 relay outputs without internal protection filter module	<b>MSSP00R0PCAROBT1</b>
with additional 8 relay outputs and inputs without internal protection filter module	<b>MSRG00R0PCAROBT1</b>
with 2 relay outputs with internal protection filter module	<b>MSSP10R0PCAROBT1</b>
with additional 8 relay outputs and inputs with internal protection filter module	<b>MSRG10R0PCAROBT1</b>
Relay control unit with further 32 relays to realize the alarm	<b>MRCU0000PCAROBT1</b>
ModBus Interfaces	
Full-duplex	<b>MMBI0003</b>
Half-duplex	<b>MMBI0103</b>

## Connection and termination modules

The connection filter module (CFM) serve to connect the access cable (CCA) to the sensor cable or to combine two sensor cable segments. The protection filter module PFM protects sensors in the cable against undue voltages. The cable termination module (CTM) serves to terminate the sensor cable.

Additional external sensors can be connected through a generic sensor interface (GSI); max. 4 sensors per GSI module.

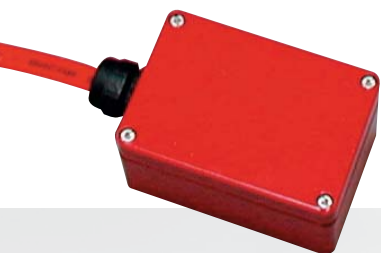

### Technical data

#### Electrical data

Current consumption	CFM: 0 mA PFM: 5 mA (typical) CTM: 5 mA (typical)
Input voltage/current	GSI sensors with 0 to 10 V or 4 to 20 mA

#### Mechanical data

Operating temperature range	-25 °C to +65 °C
Dimensions	110 x 75 x 56 mm (without cable entry)
Material	glass-fibre reinforced polyester enclosure, grey
Protection class	IP 67
Connection technology	insulation displacement connection technology with standard-tools, 8-pole connectors, grid spacing: 1.27 mm

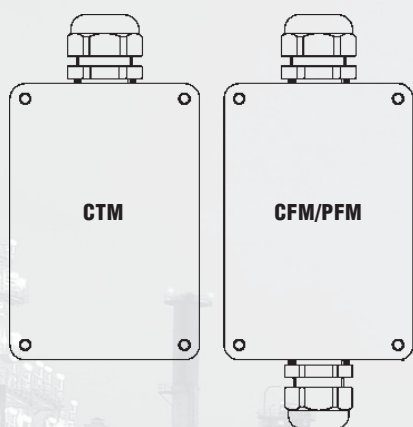

### Selection chart Connection and Termination Modules

Designation	Order no.
<b>CTM</b> Cable Termination Module	<b>MCTM00ROPEFGRBT1</b>
<b>CFM</b> Connection Filter Module	<b>MCFM00ROPEFGRBT1</b>
<b>PFM</b> Protection Filter Module	<b>MPFM00ROPEFGRBT1</b>
<b>GSI</b> Generic Sensor Interface	<b>MGSIO0ROPEFGRBT1</b>

## Accessories



### Selection chart Accessories

Designation	Order no.
Voltage source 85 to 264 V/ 24 V, 1 A Rail DIN	<b>VAC100</b>
Voltage source 100 to 240 V/ 24 V, 0.9 A	<b>VAC102</b>
<b>CCA</b> input lead	<b>VAC010</b>
Mounting clamps, VP 100 pcs.	<b>VAC020</b>
Mounting tool	<b>VAC090</b>

## Software

The RGCC (RedGuard® Control Center) software is simply installed on a WINDOWS operating system (2000 and XP). This software offers all functionalities for safely configuring, operating and maintaining the RedGuard® System:

- Output of the entire set of a plant's parameters to a PDF document (reporting)
- Project-related administration and traceability of all plant data and interventions.
- Sensor calibration: recalibration in the field, assignment of the calibration data to the sensors.
- Easy programming of the threshold readings with the aid of the reaction matrix
- Configuration of the relay output (logical equations)
- Administration and interpretation of the event logger (LOG data)
- Graphic display with zoom and pan functions

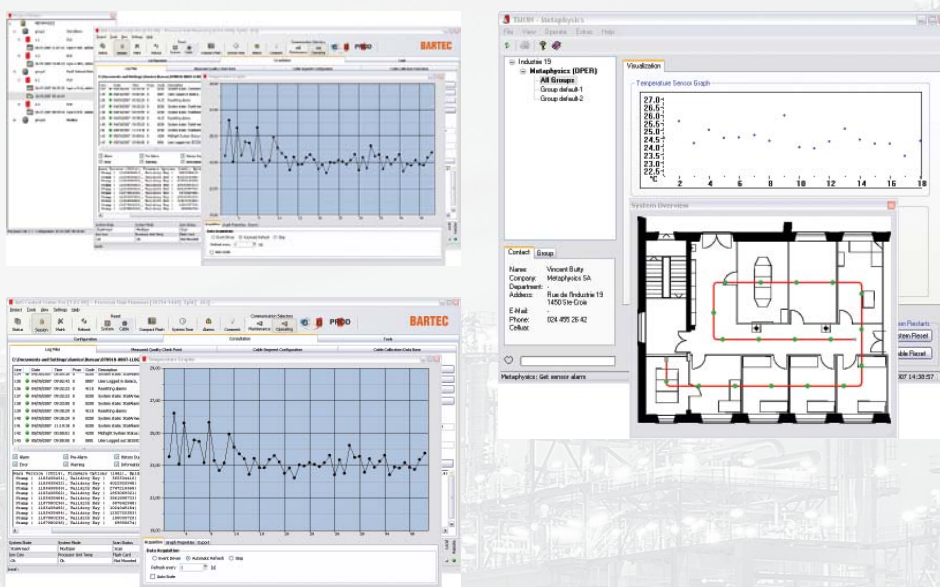

### Data certification

The history of every log and configuration file is always traceable. Each file has a content-dependent code, with which the authenticity of the contents can be verified.

### External data analysis

Data can be read into a standard table calculation program. This allows, for example, sensor values that correspond to particular critical operating states in the plant to be registered and presented.

### Project management

Several processor units can be combined for projects.

### Order numbers

Software	Visualisation Software TMON	<b>PTMON0001</b>
	Configuration Software RGCC	<b>PRGCC0003BT1</b>



## ATEX Version

### Temperature sensor unit CTU-2 for zone 1 + 21 and zone 2 + 22

For applications in hazardous areas we offer you a special configuration of the RedGuard® temperature monitoring system. The Ex version conforms to ATEX Directive 94/9/EC and is tested and approved for use in gas areas (zone 1) and dust areas (zone 21).

The CTU-2 temperature sensor unit conforms to Equipment Category II 2G and II 2D and can be used directly in hazardous areas.

The SSP or SRG processor unit is installed outside the hazardous area and is equipped with current and overvoltage protection.

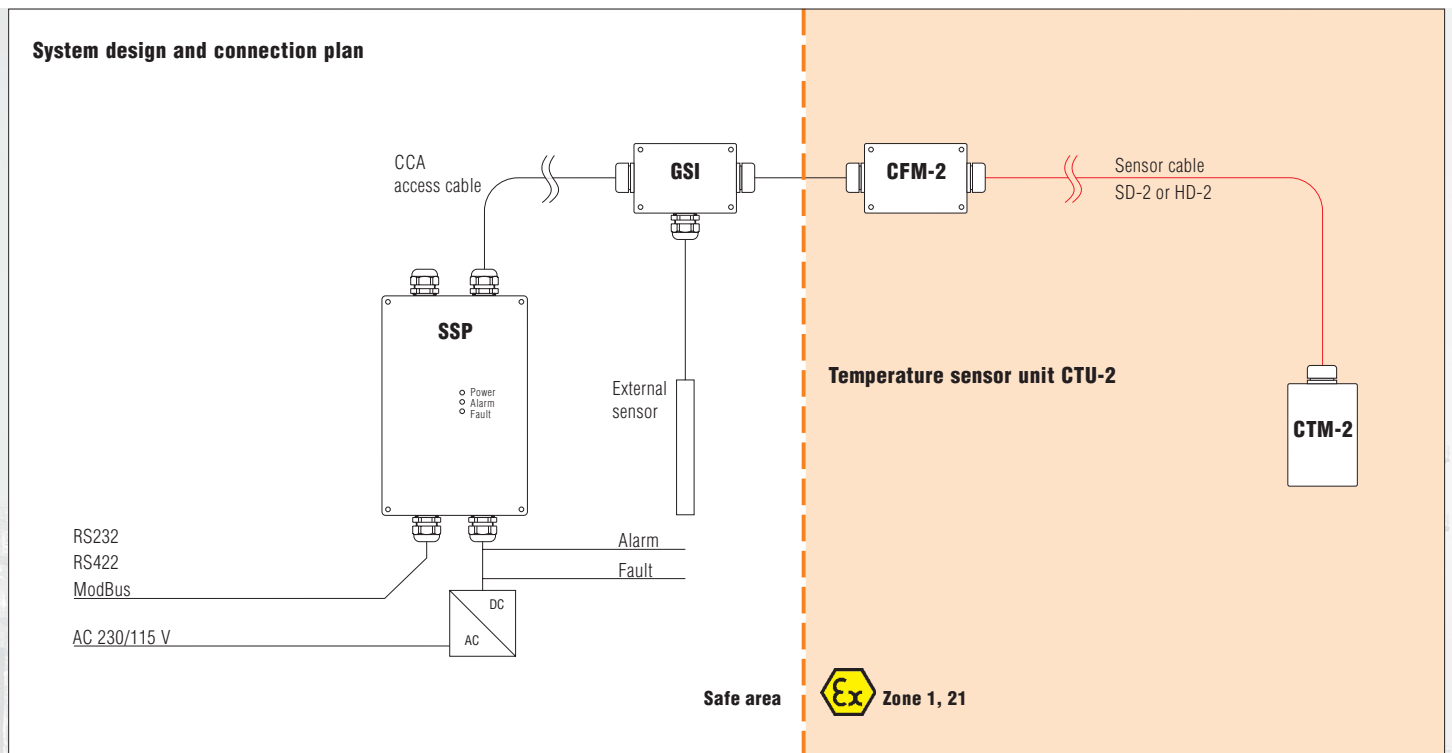

## Technical data

Explosion protection	II 2G Ex emb II T6 II 2D Ex tD A21 80 °C IBEU07ATEX1149 X
Protection class	IP 67
Ambient temperature	Sensor cable SD-2    -20 °C to +70 °C (short-time to +90 °C) Sensor cable HD-2    -20 °C to +80 °C (short-time to +115 °C)
Operating temperature	-20 °C to +65 °C
Supply voltage	20 V
Current consumption	< 32 mA
Outer jacket sensor cable	SD-2 polyurethane HD-2 fluoropolymer
Enclosure material	
Connection and termination module	Polyester, black



## Configuration

The temperature sensor unit consists of a sensor cable, connection module and termination module. The sensor cable comes in a choice of a polyurethane version or a fluoropolymer version.

Temperature sensor unit	Sensor cable	Connection module	Termination module
<b>CTU-2</b> for Zone 1, 21	<b>SD-2</b> (Polyurethane)	<b>CFM-2</b>	<b>CTM-2</b>
	<b>HD-2</b> (Fluoropolymer)		

The CTU-2 temperature sensor unit may only be operated in connection with special versions of the **SSP** or **SRG** processor units.

## Order numbers

### Sensor cable

Selection chart Sensor cable	
Sensorspacing	Code no.
2 m	<b>020</b>
4 m	<b>040</b>
7 m	<b>070</b>
10 m	<b>100</b>
20 m	<b>200</b>

**Complete order no.**  
Please enter code number.

- SD-2** Polyurethane outer jacket
- HD-2** Fluoropolymer outer jacket

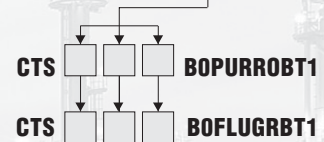

### Connection and termination module

- CFM-2** Connection Filter Module
- CTM-2** Cable Termination Module

Order no.

- MCFM00BOPEFNOBT1**
- MCTM00BOPEFNOBT1**

### Processor units specially for CTU-2

- SSP** 2 relay outputs
- SRG** 8 relay outputs

- MSSP11BOPCAROBT1**
- MSRG11BOPCAROBT1**